

Accurate

3528 East 16th Street • Los Angeles, CA 90023

1-888-ACCU-372 • 323-269-4985 • Fax: 323-269-1205

www accuratefishing.com



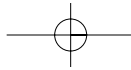

PLATINUM TWINDRAG REEL

USAGE MANUAL



Accurate



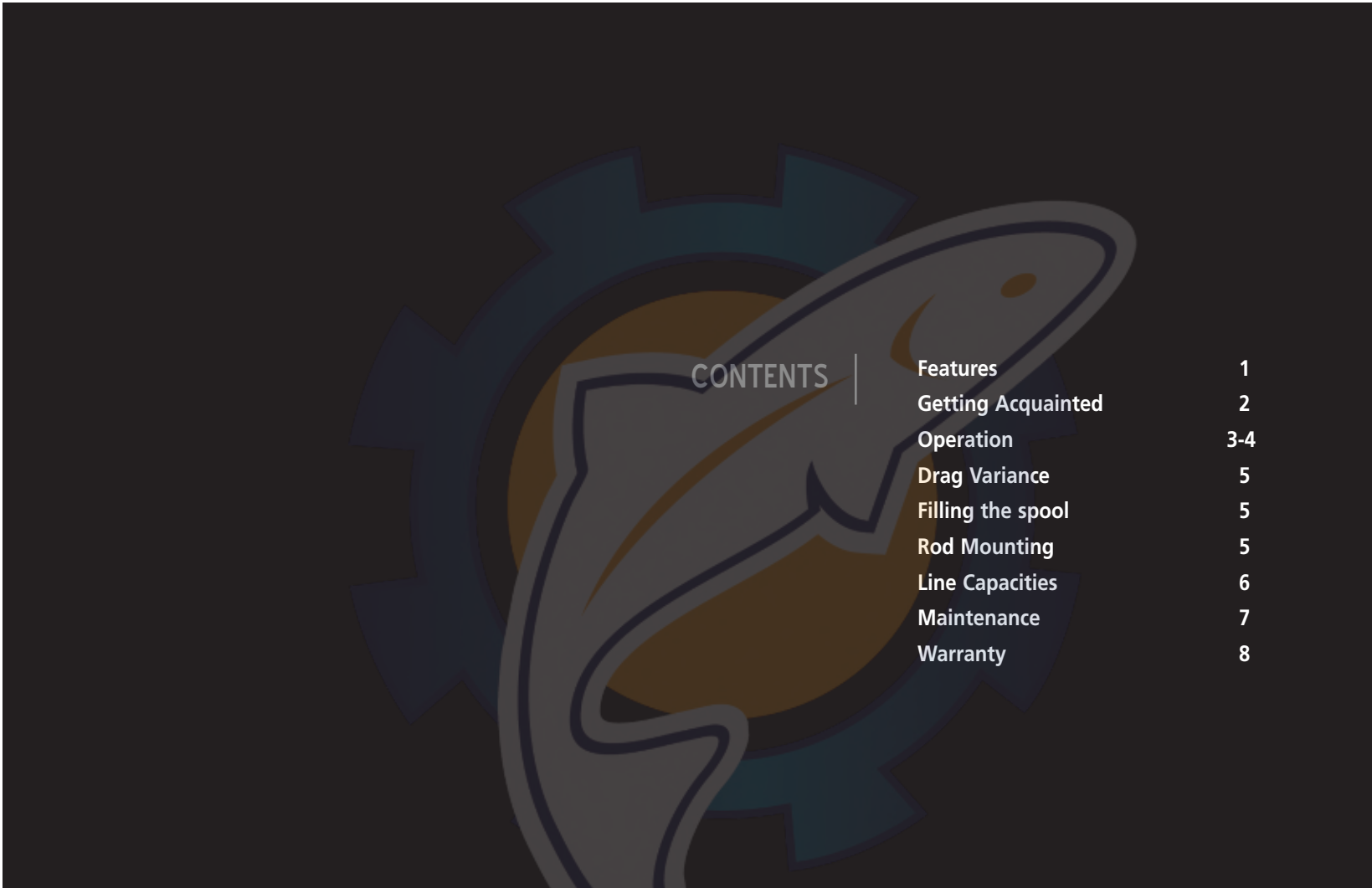
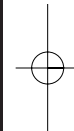
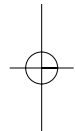
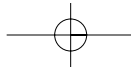

CONTENTS

Features	1
Getting Acquainted	2
Operation	3-4
Drag Variance	5
Filling the spool	5
Rod Mounting	5
Line Capacities	6
Maintenance	7
Warranty	8

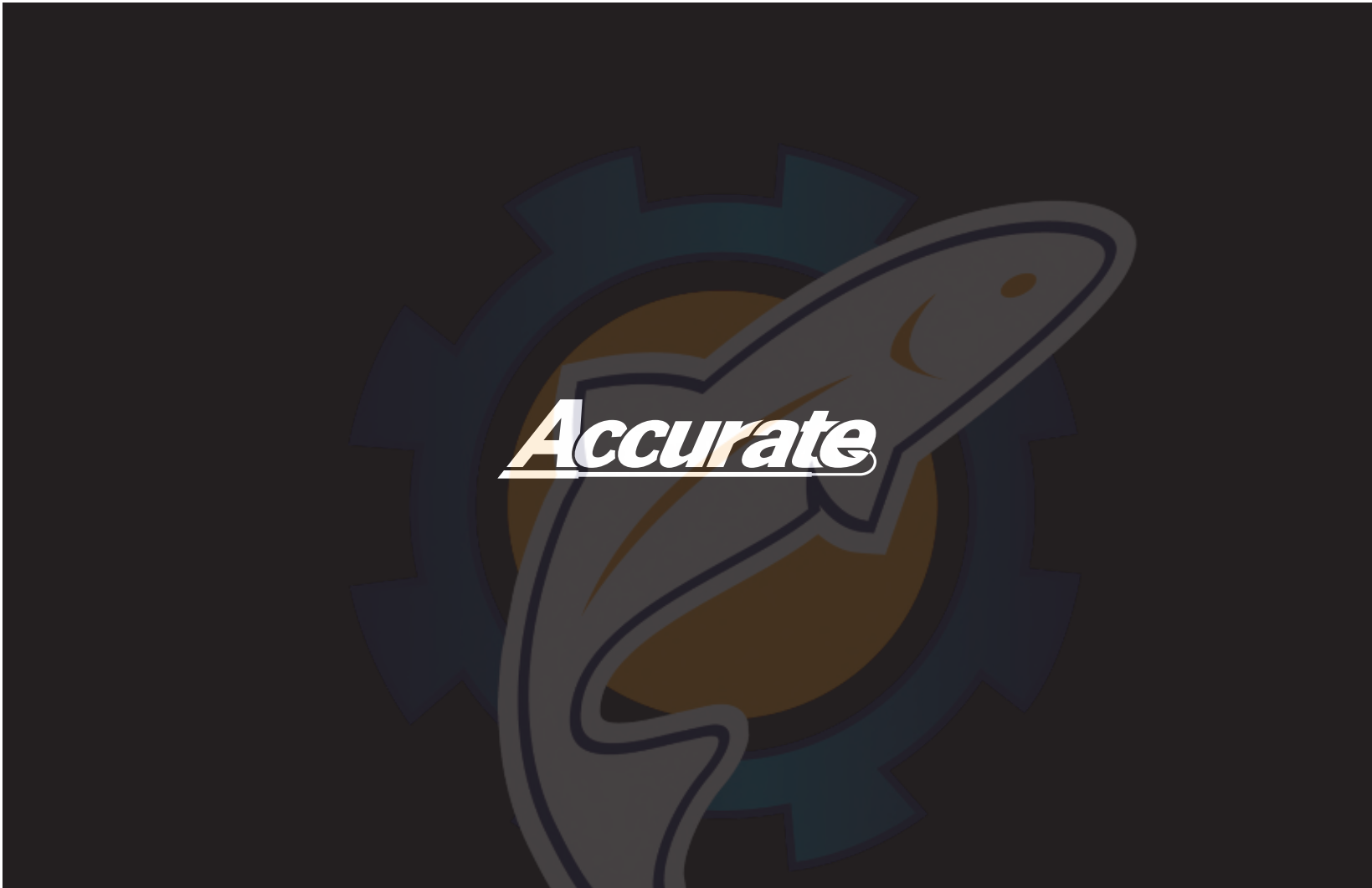
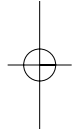
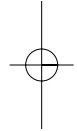
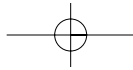

GETTING ACQUAINTED

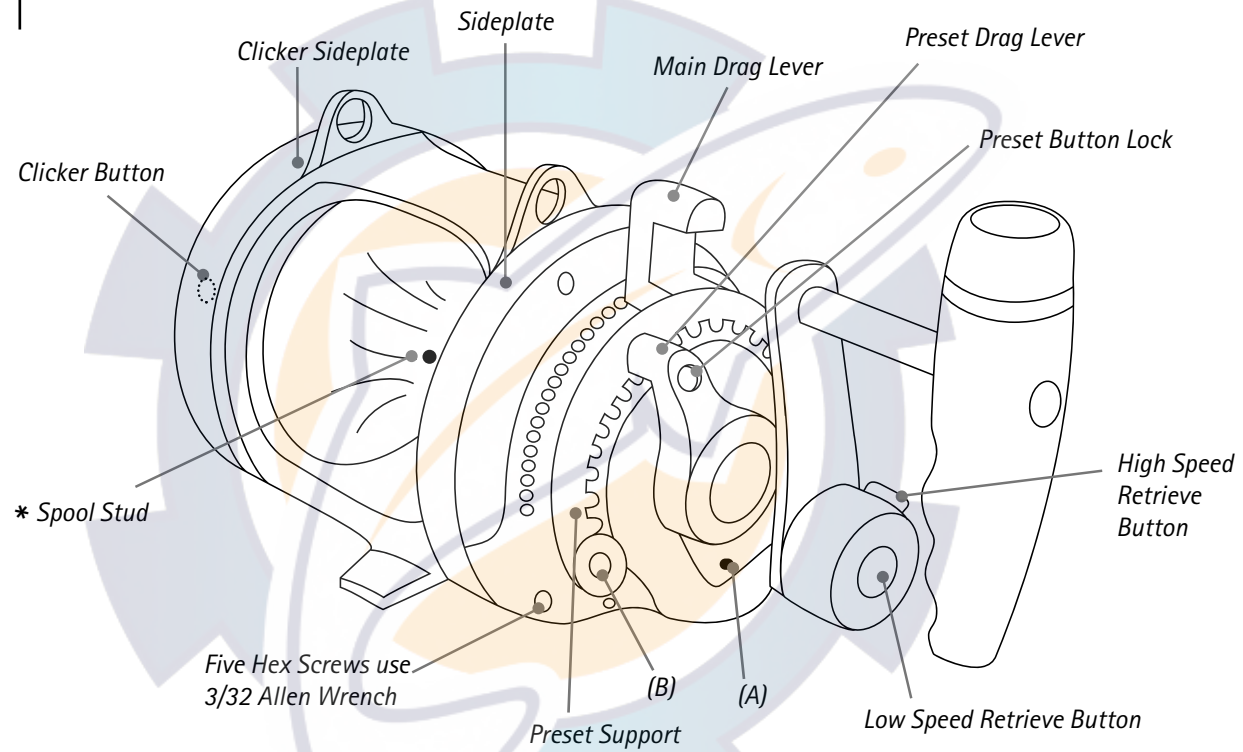

* The spool stud for tying the line to the reel can be removed with a phillips screwdriver.

MAINTENANCE

Bearing Maintenance - The Class 5 A.B.E.C. bearings in the ATD are teflon impregnated in the ball bearing race; thus, no lubrication is needed for these bearings.

NOTE: Do not lubricate the two small weep holes on the bottom of the reel. These holes are for water to drain out of the reel.

Wash down your ATD with fresh water after each use. We recommend lightly spraying it to prevent water from being forced inside. If heavy pressure is needed put the reel in the "Full" drag position. Do not completely submerge the reel into water. Wipe the exterior parts with an anti-corrosion lubricant. We recommend Corrosion X® by Corrosion Technologies. Use a good quality reel oil to lubricate all the parts indicated with the oil symbol.

Periodically, check all exterior screws to make sure they are tight. Screws may loosen over time with boat vibrations.

We recommend yearly maintenance of your ATD reel with a service professional. Preventative maintenance of your ATD reel will keep the internal parts in proper working condition and prolong the life of the reel.

Storage - When storing your ATD reel, put the reel in "Free Spool" and the clicker in the on position.

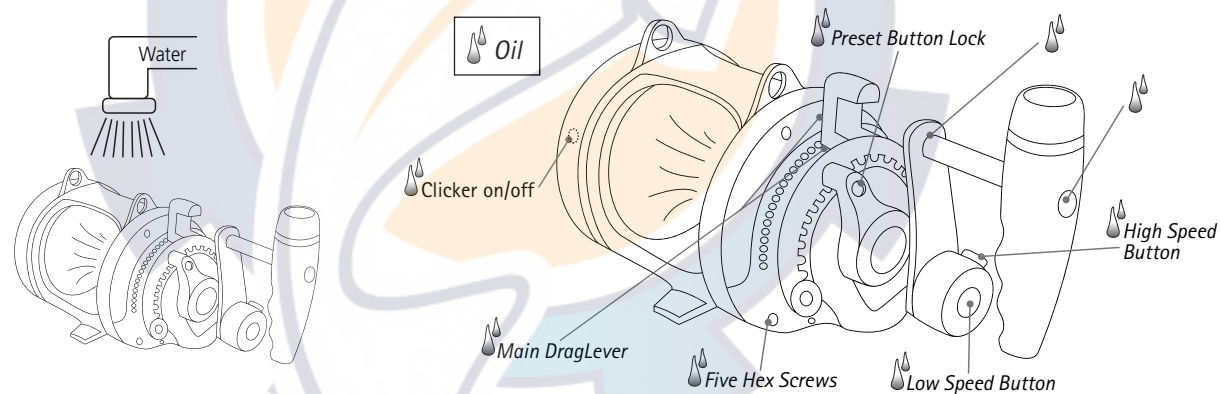

WARRANTY

NOTE: *Your reel MUST BE registered with Accurate Fishing Products in order to receive warranty service. Please send in your warranty registration card immediately after purchase.*

Thank you for purchasing an Accurate Platinum Twin Drag Reel. The reel you have chosen has been made with extreme passion and pride. It has been manufactured with the finest materials available.

Accurate Fishing Products warrants your Platinum ATD reel for a period of 5 years from the date of purchase for defects in materials or workmanship when the reel is used as it was intended.

In the unlikely event that you should experience any difficulties with you Platinum TwinDrag Reel, our customer service team is ready to help.

If we need to service your reel and you wish to send it to us or another authorized Accurate service center, please be sure to follow these instructions.

NOTE: *For warranty claims the reel must be registered to its owner and accompanied by a sales receipt.*

- 1) Pack your reel securely in a sturdy box.
- 2) Include any parts that have been removed.
- 3) Include a written letter describing the service your reel needs.
On the note be sure to include: Your name, address and phone number so we can contact you if necessary.
- 4) Be sure your package is insured and mailed with a shipping company that has tracking capabilities.
- 5) If the service you require is not under warranty and you would like an estimate before we begin the repairs, please include a self addressed, stamped envelope with your reel.

FEATURES

- > Patented TwinDrag™ system
- > Billet 6061 - T6 aluminum
- > 7 Class-5 ABEC stainless steel ball bearings
- > Preset lever with lock and alphanumeric scale
- > QuickShift two-speed
- > Titanium drag friction washers
- > Unhindered free-spool at every drag setting
- > Removable spool stud
- > Dry AccuDrags
- > 2 Anti-reverse dogs
- > Stainless-steel gears, springs, harness lug, head screws
- > Power handle - Ergonomic designed for comfort and a sure grip
- > 5-year complete warranty
- > AccuCare reel service
- > Proudly designed and manufactured in the USA
- > Left-handed models available

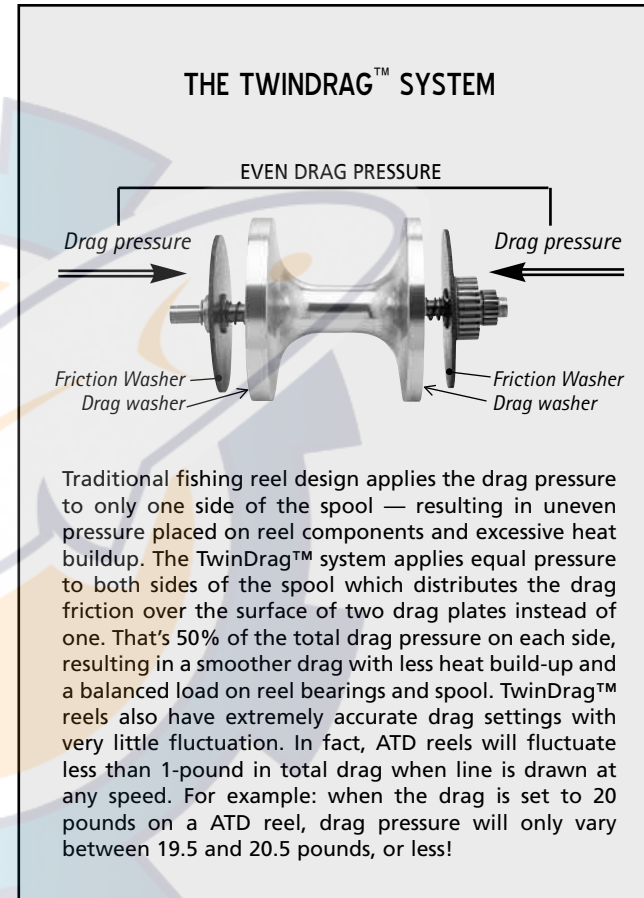

To adjust the clicker for more or less intensity, remove the six 3/32 hex screws on the sideplate. Pull the sideplate apart from the frame. You now have access to the clicker mechanism inside the frame. Pull the ring apart for less intensity or push closer together to add intensity. Once adjustment is complete, place the sideplate and spool back into the frame. Reattach screws.

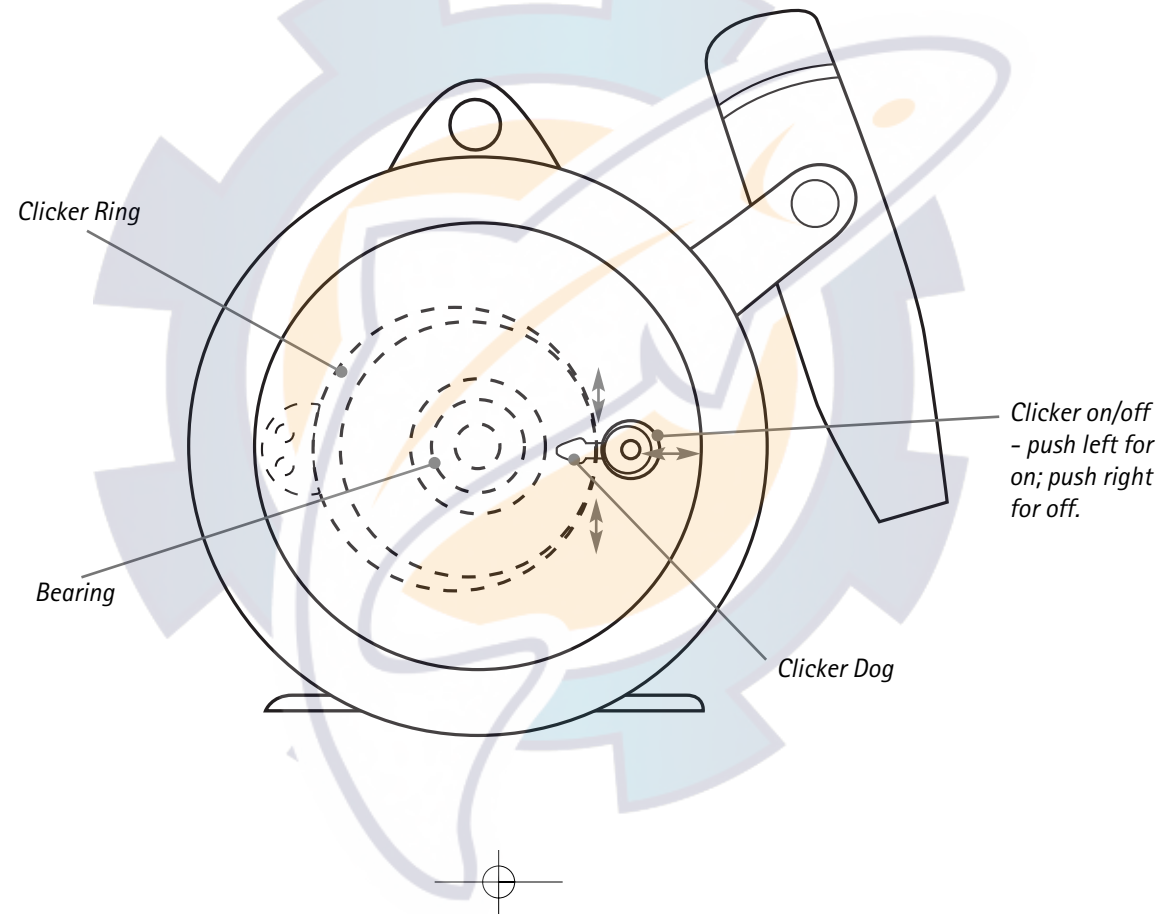

DRAG VARIANCE

Thanks to the Platinum Twin Drags exclusive Twin Drag technology, the drag tension you set will vary no more than two pounds when line is pulled off the reel at any speed! Unfortunately, there is another factor which causes drag variance that needs to be accounted for. This factor is based on how full the reel is with line. When the spool is filled, the line is being pulled off a high point on the spool. As the amount of line on the spool reduces, the line is pulled from a lower area on the spool. There is less leverage used when the line is pulled at a lower level, which means the line needs more force to move the spool against the drag. The drag setting has not been decreased, but the line will encounter increased tension. Account for the drag pressure to approximately double when 25% of the line has been removed from a full spool.

FILLING THE SPOOL

Begin filling the Platinum TwinDrag Reel by attaching the line securely to the reel spool. With tension applied to the line, fill the spool to approximately 1/4" from the spool edge.

NOTE: *Filling the spool too close to the spool edge means you will have to level wind perfectly to prevent a high spot from occurring. If a high spot occurs, the reel will not allow you to retrieve all of the line. Leave room on the spool to level wind comfortably while fighting a fish.*

Because of mono compaction when using ultra light line, we recommend first filling the spool with at least 2/3 dacron line.

Mono Compaction - *Mono compaction is a problem that happens with light line. The smaller the mono line diameter, the more elasticity the line will have. The elasticity is multiplied by the amount of line put on the spool which creates pressure on the spool. When too much light line is added, the pressure can expand the spool. This could cause the reel to perform with inconsistent drag pressure or, if enough pressure is built up, break the spool in half. Always put the least amount of ultra-light line on the reel as needed.*

ROD MOUNTING

Mount the reel on the rod with its rod clamp. If your reel is a right-handed model, be sure to mount the reel with the handle on the right.

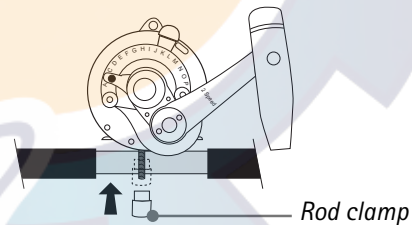

**LINE
CAPACITIES**

MODEL	WEIGHT	GEAR RATIOS	LINE CAPACITY	SPECTRA LINE CAPACITY
		High • Low	lbs./line dia. inches/yds.	lbs./yds • mono top shot
ATD-6	38 oz.	5/1 • 2.3/1	30/.022/350	50/600 • 30/100
ATD-12	42 oz.	5/1 • 2.3/1	30/.022/550	80/350 • 40/250
ATD-30	48 oz.	4/1 • 1.7/1	50/.028/400	80/400 • 60/125
ATD-50	52 oz.	3.2/1 • 1.2/1	60/.031/500	130/500 • 100/50
ATD-50 wide	54 oz.	3.2/1 • 1.2/1	80/.035/500	130/500 • 130/100
ATD-80 wide	128 oz.	3/1 • 1/1	80/.035/1000	200/1000 • 130/100
ATD-130	160 oz.	3/1 • 1/1	130/.044/1000	

OPERATION

Basic operation of your Platinum Twin Drag fishing reel is no different from operating any other fishing reel except for setting the lever drag. The most popular drag setting is to set your drag so when the **Main Drag Lever** is in the **Strike Position** it is at approximately 30% of your line strength. To obtain this setting, start by adjusting the **Main Drag Lever** so it is in the **Free Spool position**. **NOTE:** The Preset Lever cannot be adjusted unless the Main Lever is in the free spool position. Then adjust the Preset Drag Lever by depressing the Preset Button Lock and moving it to the alphabetical letter that provides 30% of drag pressure.

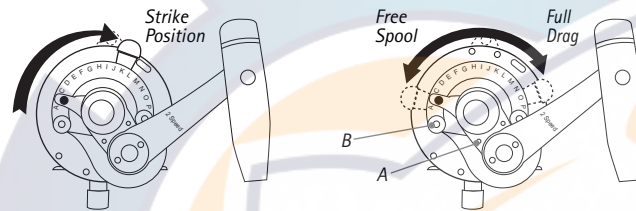

NOTE: Because the Platinum TwinDrag reels are equipped with TwinDrag technology the drag pressure you can apply is unlimited. Feel free to crank up the drag pressure to your desired setting.

If the drag Preset Drag Lever gets close to the "O" position then the Preset Lever needs to be adjusted to account for drag washer wear. Simply remove the two phillips head screws(A) and the 3/32 hex screw(B), then move the Preset Lever to the left of the Preset Support. Lift and remove the lever. Advance the nut clockwise 1/6 turn. Replace the Preset Drag Lever and move it onto the Preset Support. Replace all the screws.

Your Platinum Twin Drag Reel is equipped with both high speed and low speed retrieve settings. Use high speed for normal fishing applications and switch to low speed for extra cranking power. Your reel is delivered in the High setting. To shift to low speed push in the Low Speed Button. To shift to high speed depress the High Speed Button. It is possible to shift from low to high (with practice) very quickly. If so, you will need to pull the handle knob back (counter-clockwise) toward you in order for the gears to shift. This is because you have shifted while keeping constant pressure on the gears. Action will unload the gear pressure to allow the internal gear shift movement.