

MODEL 455B (CENTRE PIN STYLE)

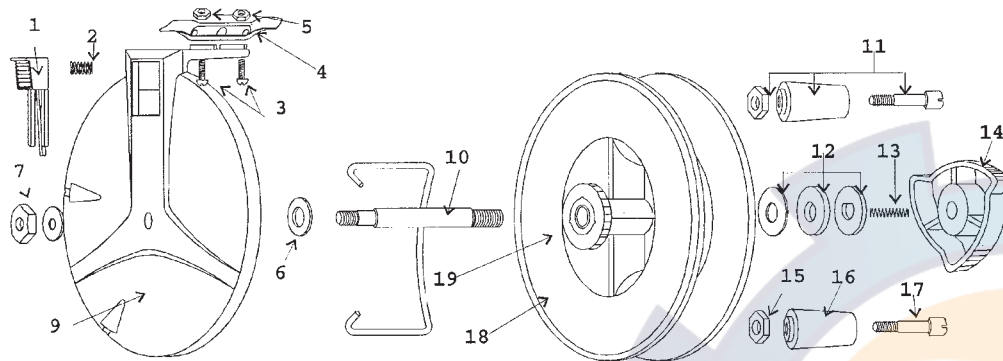

Blackfish Reels
special purpose

AUSTRALIAN MADE • AUSTRALIAN OWNED

CONGRATULATIONS and thank you for purchasing one of our Blackfish Reels as your choice of fishing reel. These reels are constructed from the highest quality materials to ensure your reel will last for many years.

A range of reels are available to suit the first time Black Fish or (Luderick) angler right through to the hard core float fisherman looking for a reel with dual ball bearings that run as smooth as silk.

Models are available with Easy Cast System, Side Cast System or non casting for those anglers who appreciate a choice

| KEY NO. | DESCRIPTION | PART NO. |
|---------|--|----------|
| 1 | RATCHET ASSEMBLY | R5E9 |
| 2 | DRAG LEVER SPRING | R5H2 |
| 3 | BASE BOLT | R2D4 |
| 4 | BASE WITH RIVETS | R2C4 |
| 5 | BASE BOLT NUT | R2F2 |
| 6 | SPINDLE FIBRE WASHER | R6J1 |
| 7 | SPINDLE HEX NUT | R6F2 |
| 9 | BACK PLATE ASS. (All Parts Except R4B) | R1A |
| 10 | SPINDLE | R6A21 |
| 11 | HANDLE ASSEMBLY | R4F4 |
| 12 | SPINDLE WASHER SET | R6L1 |
| 13 | SPINDLE SPRING | R6C7 |
| 14 | SPINDLE NUT | R6B10 |
| 15 | HANDLE LOCK NUT | R4G1 |
| 16 | HANDLE ONLY | R4D3 |
| 17 | HANDLE SCREW | R4E4 |
| 18 | SPOOL WITH HANDLES | R4B |
| 19 | RATCHET WHEEL | R5B6 |

Plus all these other advantages...

LONG, ACCURATE CASTS:

Now, with only the minimum of practice following Alvey instructions, you'll be able to cast further and more accurately than ever before.

CONTROL LARGE FISH WITH EASE:

Powerful one-to-one direct wind means you only need about a quarter of the effort required to lift a similar weight on a spinning reel.

YOU CAN FISH HARDER AND LONGER:

Simple, rugged construction means you can forget that fiddly maintenance, because your Alvey reel will resist the effects of salt water and sand.

MORE COMFORTABLE FISHING:

Low winch mount rods let you fish with your arms in a relaxed position.

DID YOU KNOW Alvey reels are fish sensitive?

Angling with an Alvey side-cast or boat reel means you're using a system that lets you 'feel' the bite directly through the handles as well as through the fingers you use to guide the line. No other reel gives you this unique direct contact with your bait or lure- and the fish.

NO LINE TWIST:

Use a small free-running swivel as the last piece in any rig and you'll never have line twist. (See illustrations inside)

GUARANTEE AGAINST FAILURE:

If your Alvey reel should ever fail because of faulty workmanship or materials, just return it to the place of purchase or to the factory and we'll repair it. Without charge.

Should replacement of drag or ratchet action springs be necessary refer to the illustration below.

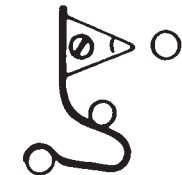

METAL BACKED RATCHET SPRING

RECOMMENDED LINE SIZE

For fish up to 2kg use 3 to 4kg line, fish 2 to 4kg use 5 or 6kg line, for larger fish use 7.5 to 10kg line. If fishing near rocks or other hazards use heavier line to help avoid line breakage.

FILLING THE SPOOL WITH LINE

Always take the line from the front of the spool, spreading the line to give a smooth casting base.

Wind on firmly and evenly onto the spool, spreading the line to give a smooth casting base.

Never stretch a nylon monofilament onto a spool, when it goes back to its original length it will exert strong enough crushing action to

damage your spool. Never allow loose coils to develop on your spool through careless uneven winding. Adopt the habit of applying light finger tension while the line is spread evenly over its bed.

SELECTING A ROD

Your rod and reel outfit should be designed so you can hold it comfortably over long periods. A matched set, which has a point of balance where its held in the left hand, will give you the most comfortable posture.

The use of a short butt brings the reel into a natural position for rewinding with your elbows at your side and without strain.

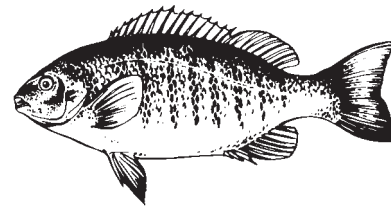

The Luderick or blackfish is a small mouthed, weed-eating fish, and is one of the greatest light gear fighters of its size.

As the premier method used is float fishing, and it is preferable to have your line from rod tip to float, out of, or on top of the water, heavy lines are out. .30 will do, but if your ability lets you, use .25. The best bait for the estuary is Alga weed, sometimes called Moss or Greenweed, which is plaited a few times around the hook shank, and trail of 15mm is left below the hook. As this weed swells in water it pays not to over bait. The Ulva weed (Sea cabbage) also produces some fish in the estuary particularly if the smaller new growth leaves are used. Sometimes Luderick will take yabbies, prawns and worms, but this is not their regular diet, as they are a herbivorous fish and their natural bait is weed. To keep fish active in your area it is necessary to have a good supply of burley, made from 1/2 loaf soaked bread, 2 handfuls of Bran and some finely chopped moss. Mix with sand and in a running tide, select sand with a fair deposit of mud. Feed small squeezed lumps into the water slightly up-tide. Remember that indiscriminate use of burley without thought can give opposite to the desired effect.

Your method of fishing is firstly to determine the depth. When your bait touches bottom, the float will lie sideways. Alter your float stop and start trying with bait just clearing the bottom. If you get no result lift your bait up a foot and so on. At times they come on 1 metre above the bottom.

Your 'Strike' is made with the rod laid slightly sideways against the way the float and fish are travelling. Always allow your float to go well down before attempting to hook the fish.

Take your time, it will tire. To protect your light line, lift the fish from the water with a landing net.

Luderick spots in the estuary are fairly constant. The areas to explore would be deep water banks where there would be sunken timber, rocky reefs, sunken hulks, or such like obstructions underwater. Around the piles of bridges and jetties is another favourite haunt. Along rock walls, particularly where deep water holes, or changing wall formation has caused a tide to eddy or swirl, can give an area to fish successfully at all stages of a tide.

These fish dislike clear sunlit water, a cloudy day with the water slightly discoloured brings the best fishing. The good tide is largely dependent on the area, but the last two hours of the ebb tide and the first hour of the flood tide, particularly if occurring around dawn or dusk, are the conditions most sought.

ALVEY DIRECT WIND REELS

The ultimate in simplicity of construction, with the absolute minimum of wearing parts. 'A' and 'B' Series reels have no star drag action. As the fish makes its run, even-line tension is maintained by the angler taking his or her fingers from the winding handle and putting them under the reel against the line still left in the spool well.

PLAYING THE FISH

Once the fish has been hooked always keep a bend in the rod by holding it at an angle to the fish. With the power of an Alvey reel, you only need to hold the rod up and wind in. If the fish is too strong, let go some line until it tires then rewind. With large fish, pumping with the rod will help in landing it.

MAINTENANCE

Use Alvey reel Lube for working spindles etc. Then light machine oil on handles and index mechanism. After each day's fishing wash off salt and sand and lubricate as above before storage. Unless major overhaul is required, there's no need to strip the reel completely.

RIGS & SWIVELS

When used properly a brass swivel is a very inexpensive and efficient way to keep a fishing line in good condition.

Curls and twists in a line can be caused by many things, but can be kept to a minimum by a correct use of a swivel.

All reels that cast from the side of a stationary spool give maximum unrestricted casting, free from snarls or backlash, but it's essential that a small free running swivel is used as the last item above the rig.

The swivel must be above the weight. Whatever the rig always use the smallest practical swivel above any attachment to the line.

SWIVEL SIZES

- Size No. 12 Lines 3 to 5kg breaking strain.
- Size No.10 Lines 6 to 7kg breaking strain
- Size No.8 Lines 10 to 12kg breaking strain.
- Size No.6 Lines 12 to 17kg breaking strain.

TYPES OF RIG

