

Installation of IF-2901

Installation materials

The NMEA Combiner Unit comes with the installation materials listed in the table which follows.

Part	Qty	Remarks
NMEA Combiner Unit	1	
Installation Instructions	1	
Cable Tie	4	
Self-tapping Screw	2	
Jumper Wire	2	For MODEL 1831/1931/1941
Lead Wire for power	2	For MODEL 1831/1931/1941, one each of brown and red
Crimp-on Lug	8	

Modification of radar

Be sure the power to the radar is turned off and all plugs at the rear of the display unit are disconnected before beginning the modification.

MODEL 1621

- 1) Referring to the figure which follows, unfasten four screws and three connector nuts.

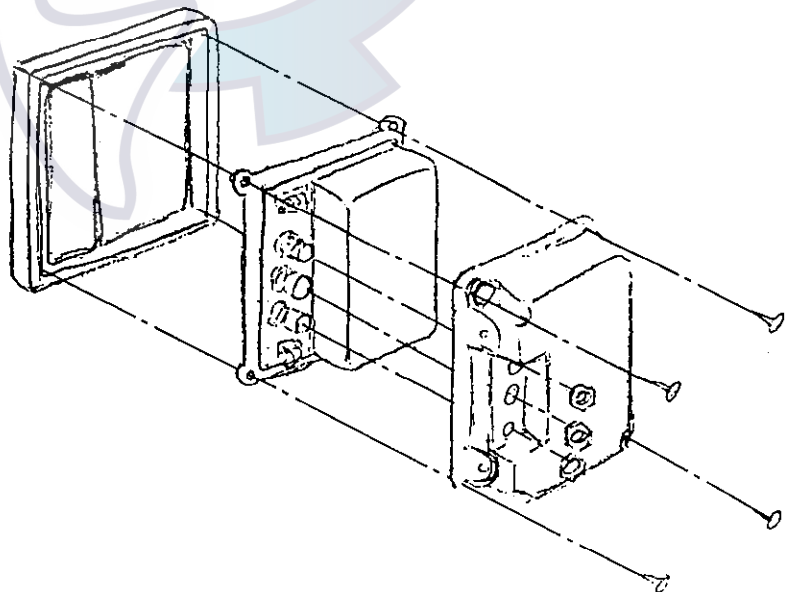

- 2) Push the connectors lightly to remove the rear cover. Dismount the DU Board.
- 3) Attach a jumper wire (prepare locally) to both "JP3-A" (for + 5 V line) and "JP3-B" (for GND), at the top of the NMEA connector, if necessary. (PCB version no.-2 has jumper wires already attached; version no.-1 does not.) See the figure which follows for location.

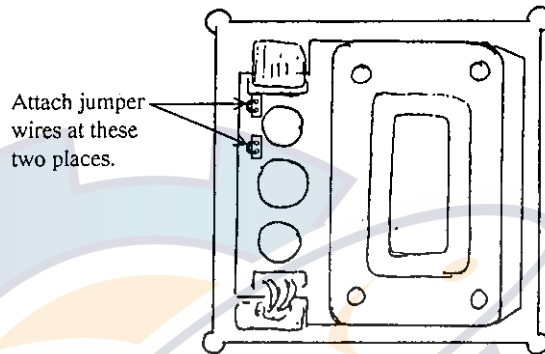

- 4) Reassemble the unit.

MODEL 1831/1931/1941

- 1) Unfasten eight screws to dismount the rear cover. Dismount the SPU Board SPU-9096 by unfastening connectors and fixing screws.

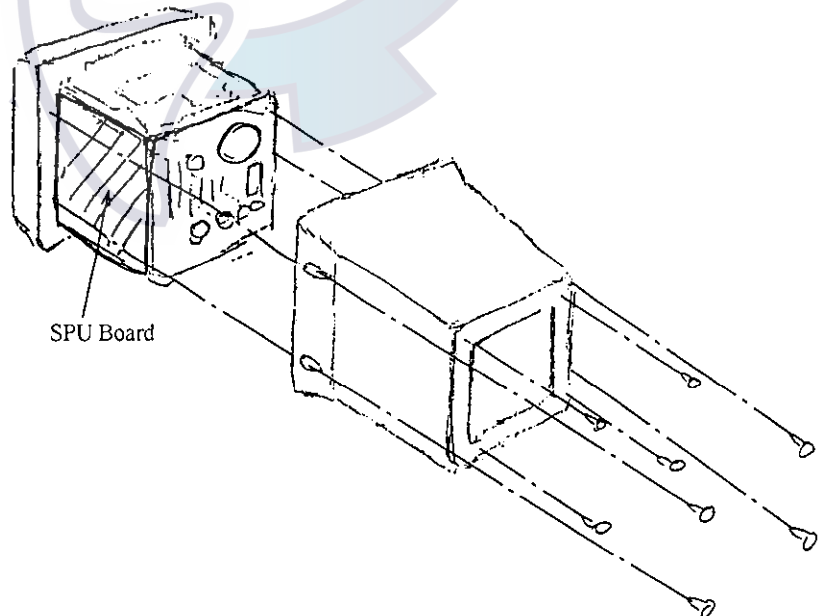

- 2) On the solder side of the SPU Board, run jumper wires (supplied) between J59 #1 and J54 #1 and J59 #2 and J54 #2. See the figure which follows for location.

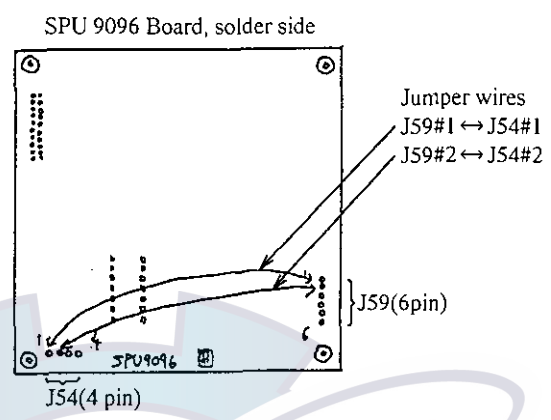

- 3) Install the SPU Board.
- 4) Unfasten the NAV connector on the rear panel by using a hex wrench.

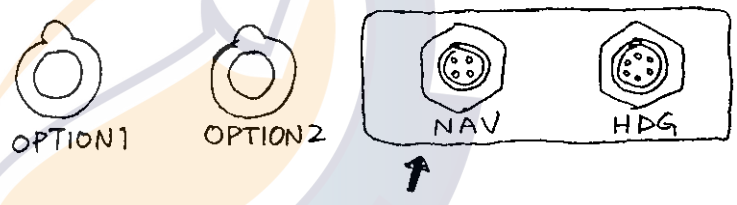

- 5) Solder red and brown lead wires (supplied) to the connector pins of the NAV connector. Bind all lead wires with a cable tie (supplied).

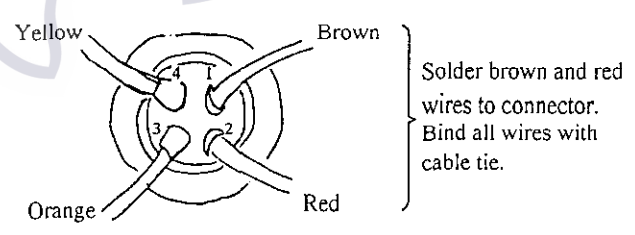

- 6) Disconnect plug P54 on the SPU Board and remove contact pins at #1 and #2. Plug in the brown and red wires into terminal pins #1 and #2, respectively.

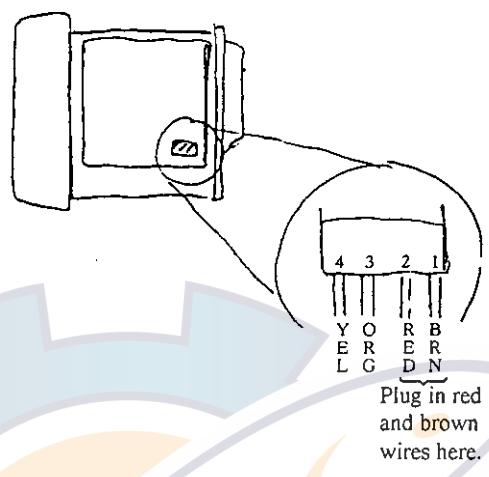

- 7) This concludes the procedure for modification of the display unit. Confirm that all connections are correct and then attach the rear cover.

Installation of IF-2901

Install the IF-2901 as follows.

- 1) Select a suitable location for the unit considering the length of cabling between it and the echo sounder and the navigator. **THIS UNIT IS NOT WATERPROOF; LOCATE IT AWAY FROM SEA SPRAY AND WATER SPLASH.**

Unfasten four screws to remove the top cover. Fix the unit to the mounting location by using tapping screws (supplied) or double-sided tape, etc.

- 2) Pass lead wires of the NMEA cables of the navigator and the echo sounder into the IF-2901. Attach crimp-on lugs (supplied) to lead wires. Connect lead wires to the terminal strip of the IF-2901 as shown in the figure which follows.

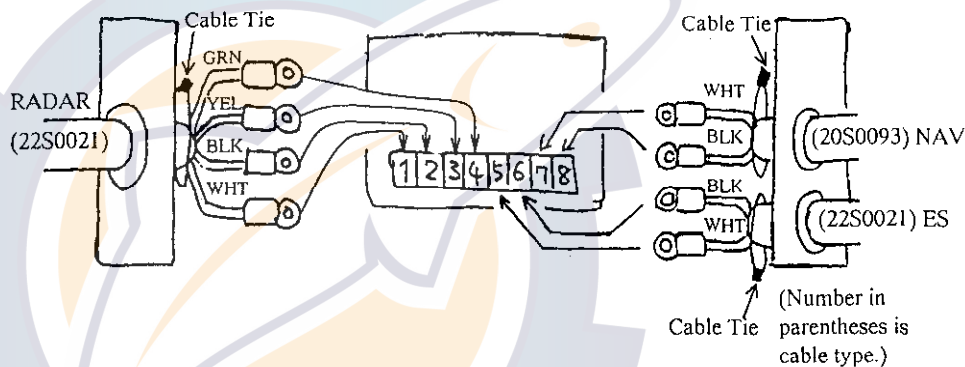

RADAR

White (+5 V): #1 pin
 Black (GND): #2 pin
 Yellow (RD-H): #3 pin
 Green (RD-C): #4 pin

NAVIGATOR

White (RD-H): #7 pin
 Black (RD-C): #8 pin

ECHO SOUNDER

White (RD-H): #5 pin
 Black (RD-C): #6 pin

- 3) Tape unused lead wires of navigator and echo sounder to prevent shorting.
- 4) Bind lead wires with cable ties. Leave slack in wires to prevent wire fatigue.
- 5) Attach the cover.

Notes on usage

- There is a maximum of six to seven second delay in receiving data from the navigator and the echo sounder. Thus those data should not be viewed as real time data.
- The Tx transmitting interval for Tx data (lat/long, waypoint, depth, speed, etc.) should be set for about two seconds, on the navigator, to prevent misreading of data.

