

# FURUNO

## OPERATOR'S MANUAL

**VIDEO PLOTTER**

**MODEL RP-180**



**FURUNO ELECTRIC CO., LTD.**  
NISHINOMIYA, JAPAN



# SAFETY INSTRUCTIONS



## WARNING

**Be sure to insert the memory card battery correctly.**

The battery may explode if it is installed with polarity reversed.

## NOTICE

No one navigational aid should be relied upon exclusively for the safety of vessel and crew. The navigator has the responsibility to check all aids available to confirm his position. Electronic aids are not a substitute for basic navigational principles and common sense.

### **Digital charts cannot replace official nautical charts**

Digital charts are intended as an navigational aid. Therefore, position should always be checked against nautical charts, as well as other aids to navigation.

### **Handle chart/memory cards carefully**

The chart and memory cards are weak against electrostatic discharge. Handle them with care, observing the following guidelines.

- Keep cards away from heat sources.
- Replace cards in their protective cases after use.

### **Replace memory card battery within 10 minutes of removal.**

Replace the memory card battery within 10 minutes of removal to prevent loss of data.

# TABLE OF CONTENTS

---

<b>FOREWORD</b> .....	<b>iv</b>
<b>1. OPERATIONAL OVERVIEW</b> .....	<b>1-1</b>
1.1 Introduction .....	1-1
1.2 Controls Used By the Video Plotter, AIS .....	1-2
1.3 Choosing Displays .....	1-3
1.4 Choosing Presentation Mode .....	1-4
1.5 Shifting the Display .....	1-5
1.6 Choosing Chart Scale .....	1-6
<b>2. CHART CARDS</b> .....	<b>2-1</b>
2.1 Displaying Charts .....	2-1
2.2 Showing/Hiding Chart Features .....	2-3
2.3 Position, Bearing Correction .....	2-5
<b>3. TRACK</b> .....	<b>3-1</b>
3.1 Displaying Own Ship's Track .....	3-1
3.2 Stopping Plotting of Own Ship's Track .....	3-2
3.3 Changing Own Ship's Plot Interval .....	3-3
3.4 Other Ship's Tracks and Plotting Interval .....	3-4
3.5 Erasing Own Ship's Track, Other Ship's Track .....	3-5
3.6 Own Ship, Target Track Color .....	3-6
<b>4. MARKS, LINES</b> .....	<b>4-1</b>
4.1 Displaying Marks, Lines .....	4-1
4.2 Entering Marks, Lines .....	4-3
4.3 Erasing Marks, Lines .....	4-5
4.4 MOB Mark .....	4-6
4.5 Origin Mark .....	4-7
4.6 Mark Color .....	4-7
<b>5. WAYPOINTS, ROUTES</b> .....	<b>5-1</b>
5.1 Turning Waypoints On/Off .....	5-1
5.2 Entering Waypoints .....	5-1
5.3 Waypoints .....	5-3
5.4 Creating Routes .....	5-4
5.5 Turning Route Display On/Off .....	5-7
5.6 Deleting Route Waypoints .....	5-8
5.7 Deleting Routes .....	5-8
<b>6. NAVIGATION</b> .....	<b>6-1</b>
6.1 Navigation .....	6-1
6.2 Cancelling Navigation .....	6-4
6.3 Skipping Route Waypoints .....	6-4
<b>7. ALARMS</b> .....	<b>7-1</b>
7.1 Arrival Alarm, Anchor Watch Alarm .....	7-1
7.2 XTE Alarm, Border Alarm .....	7-3

<b>8.</b>	<b>MEMORY CARD OPERATIONS</b> .....	<b>8-1</b>
8.1	Formatting Memory Cards.....	8-1
8.2	Saving Screen Contents to Memory Card.....	8-3
8.3	Displaying Memory Card Contents on the Display.....	8-5
8.4	Playing Back Memory Cards.....	8-6
8.5	Erasing Files from Memory Cards.....	8-7
<b>9.</b>	<b>OTHER FUNCTIONS</b> .....	<b>9-1</b>
9.1	Entering Ship's Position Manually.....	9-1
9.2	Smoothing.....	9-2
9.3	Viewing Chart Card Contents.....	9-2
9.4	Adjusting Brilliance.....	9-3
9.5	Clearing All Data.....	9-4
9.6	Restoring Default Settings.....	9-4
9.7	Marker Colors on Chart Cards.....	9-5
9.8	Apportioning the Memory.....	9-6
<b>10.</b>	<b>AIS</b> .....	<b>10-1</b>
10.1	Changing Function of [F2] Key to AIS.....	10-1
10.2	Turning AIS Feature On/Off.....	10-2
10.3	Activating Targets.....	10-3
10.4	Sleeping Targets.....	10-4
10.5	Displaying Target Data.....	10-5
10.6	Lost Target.....	10-7
10.7	Messages.....	10-7
10.8	History Display.....	10-9
10.9	AIS Symbol Color.....	10-10
10.10	Automatic Target Activation.....	10-11
10.11	Lost Target Range.....	10-11
10.12	ROT Display Setting.....	10-12
10.13	Combining AIS with ARPA (fusion).....	10-13
10.14	AIS System Messages.....	10-14
10.15	AIS Alarm Message.....	10-16
<b>11.</b>	<b>MAINTENANCE, TROUBLESHOOTING</b> .....	<b>11-1</b>
11.1	Replacement of Batteries.....	11-1
11.2	Diagnostic Test.....	11-2
<b>12.</b>	<b>INSTALLATION</b> .....	<b>12-1</b>
12.1	Necessary Parts.....	12-1
12.2	Installation.....	12-1
	<b>APPENDIX</b> .....	<b>AP-1</b>
1.	Digital Interface.....	AP-1
2.	Interface Function.....	AP-4
3.	Main Board Modification (IEC 60936-1 related items).....	AP-4
4.	Menu Tree.....	AP-5
5.	Chart Icons.....	AP-9
	<b>SPECIFICATIONS</b> .....	<b>SP-1</b>
	<b>INDEX</b> .....	<b>IN-1</b>

# FOREWORD

---

## A Word to RP-180 Owners

Congratulations on your choice of the FURUNO RP-180 Video Plotter. We are confident you will see why the FURUNO name has become synonymous with quality and reliability.

For nearly 50 years FURUNO Electric Company has enjoyed an enviable reputation for innovative and dependable marine electronics equipment. This dedication to excellence is furthered by our extensive global network of agents and dealers.

Your RP-180 is designed and constructed to meet the rigorous demands of the marine environment. However, no machine can perform its intended function unless installed, operated and maintained properly. Please carefully read and follow the recommended procedures for operation and maintenance.

We would appreciate hearing from you, the end-user, about whether we are achieving our purposes.

Thank you for considering and purchasing FURUNO equipment.

## Features

The Video Plotter RP-180 is an optional circuit board which is accommodated in the display unit of the FR-1500 MARK-3 series radars, and provides video plotter functions, such as waypoint marking and route creation, and AIS (optional).

The main features are

- Chart overlay on radar display
- Head-up display for chart card data
- Memory cards for unlimited storage of data
- Memory cards useable together with chart cards
- Radar position correction
- Alarms: Arrival, Anchor Watch, Border, XTE (Cross-Track Error)
- AIS function available with connection of AIS transponder
- Own ship's and other ships tracks available in various colors

# 1. OPERATIONAL OVERVIEW

---

## 1.1 Introduction

The Video Plotter RP-180 is an optional circuit board (RP board) which is accommodated in the display unit of the FR-1500 MK3 series radar. It permits use of two memory cards, a memory card (RAM card) for storing own ship and other ship tracks and marks, and the other is a chart card (ROM card) for digital charts.

With connection of an AIS (Universal Automatic Identification System) transponder to the RP board, the RP-180 provides navigation data about vessels which carry an AIS transponder.

10 navigation lines may be stored and each line may contain up to 30 waypoints. 100 waypoints are available. The user may enter position data in waypoints 01-98. (Waypoint 00 is for own ship position when destination is set; waypoint 99 is for waypoint from external equipment.) Own ship and other ship tracks may be stored at a selected interval.

Charts are superimposed on the radar picture without disturbing the radar observation. The chart area is dependent on the radar range in use. The RP-180 comes in two versions according to chart to be used: FURUNO/NAVIONICS and FURUNO/C-MAP.

## 1.2 Controls Used By the Video Plotter, AIS

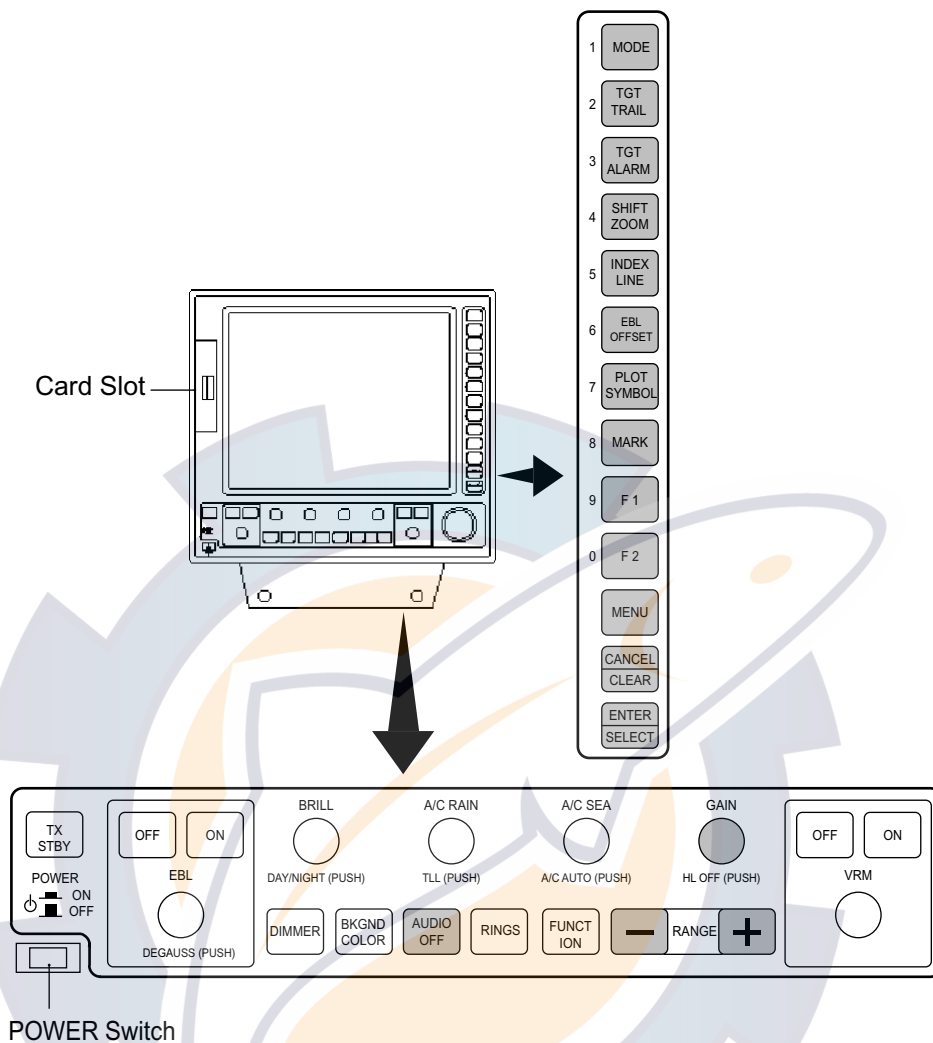

### Controls used by the video plotter

- MODE:** Chooses presentation mode.
- SHIFT/ZOOM:** Offcenters the display (momentary press); zoom feature (long press).
- MARK:** Inscribes mark.
- Numeric keys:** Enter alphanumeric data.
- AUDIO OFF:** Silences audible alarm.
- MENU:** Opens/closes the menu.
- CANCEL/CLEAR:** Clears entire line of data; erases marks, cancels selection.
- ENTER/SELECT:** Registers data.
- HL OFF:** Temporarily erase the RP screen.
- RANGE:** Chooses radar range.

### Controls used by the AIS

- F2:** Opens AIS menu.
- CANCEL/CLEAR:** Erases lost target.
- ENTER/SELECT:** Displays data for the target selected.
- AUDIO OFF:** Silences AIS-related audible alarm.

## 1.3 Choosing Displays

The RP-180 has three displays: Radar, Video Plotter, and Combination (radar + video plotter). Displays may be selected on the Video Plot/AIS menu as follows:

1. Press the [MENU] key.
2. Press the [1] key twice to show the VIDEO PLOT/AIS menu.

### VIDEO PLOT/AIS MENU

1. Radar Disp
2. Combination Disp
3. Video Plot Disp
4. Waypoint
5. Route
6. Destination Set
7. Plot Interval
8. Memory Card
9. Coastline/Mark Disp
0. AIS/Miscellaneous1

### VIDEO PLOT/AIS menu

3. Press the [1], [2] or [3] key to choose the mode desired.
4. Press the [MENU] key to close the menu.

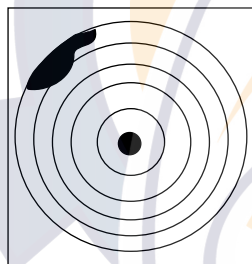

Radar Display

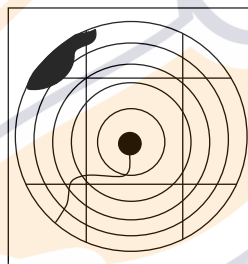

Combination Display

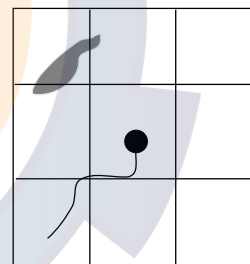

Video Plotter Display

### Displays

**Note 1:** The combination display requires heading signal. When the heading signal fails, the radar display is automatically selected.

**Note 2:** The RP-180 may be used with the IMO-specification radar, however the video plotter display is not available.



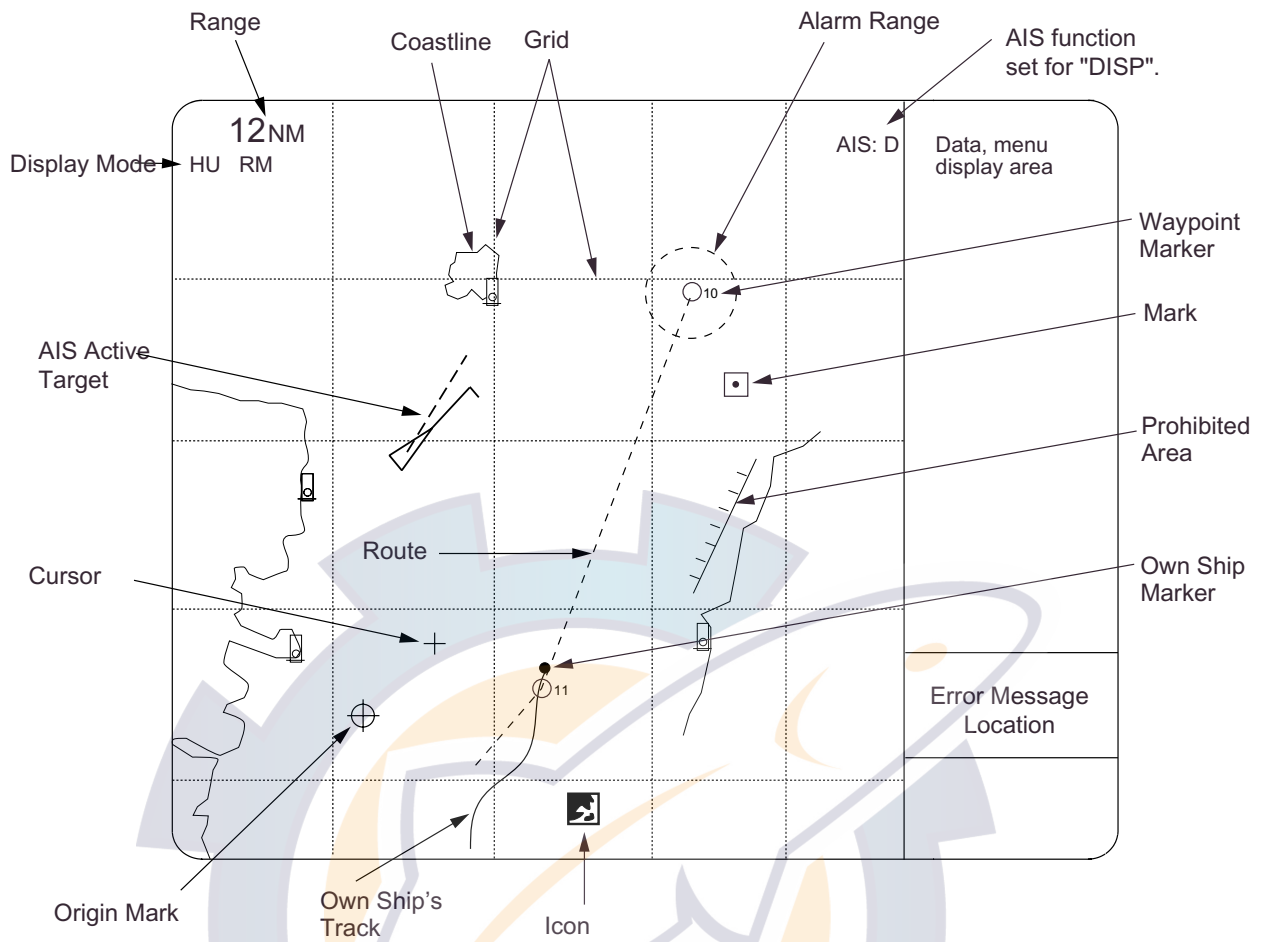

## 1.4 Choosing Presentation Mode

Five presentation modes are available by the [MODE] key: head-up, head-up true bearing, course-up, north-up, and true-motion. (North-up, head-up true bearing, course-up and true motion require a heading signal. TM mode additionally requires a speed signal.) Each time the key is pressed, if heading is input to the radar, the display and the display mode indication at the top left corner of the display change in the sequence of HU, HU TB, CU, NU and TM. If there is no heading signal input, the display mode is always HU.

## 1.5 Shifting the Display

### 1.5.1 Shifting by the trackball

The display can be shifted by the trackball up to 75% of the range in use in any direction. Operate the trackball to shift the display, and the display shifts in the direction the trackball is operated. When the cursor reaches an edge of the display, the pictures shifts in the opposite direction.

### 1.5.2 Offcenter

Own ship position, or sweep origin, can be displaced to expand the view field without switching to a larger range scale. The sweep origin can be offcentered to a point specified by the cursor, up to 75% (50% in the true motion mode) of the range in use in any direction.

This feature is not available on the 72 nm range or higher.

To offcenter the radar picture:

1. Place the cursor at a position where you wish to move the sweep origin by operating the trackball.
2. Press the [SHIFT/ZOOM] key momentarily. Then, the sweep origin is offcentered to the cursor position. However, the heading line is left in the same position.
3. To cancel offcentering, press the [SHIFT/ZOOM] key again.

### 1.5.3 Zoom

Zoom enlarges an area of interest as large as twice the normal viewing. This feature is available on the IMO-type radar only.

1. Place the cursor (+) close to the point of interest by operating the trackball.
2. Press and hold down the [SHIFT/ZOOM] key for about two seconds. The area around the cursor and own ship is enlarged twice as large as the original size.
3. To cancel zoom, press and hold down the [SHIFT/ZOOM] key about two seconds.

**Note:** The zoom feature is inoperative when the display is off centered.

## 1.6 Choosing Chart Scale

The chart scale can be selected with the [RANGE+] and [RANGE-] key. A larger range shrinks the picture; a smaller one enlarges it.



## 2. CHART CARDS

---

### NOTICE

Chart cards are intended as an aid to navigation. The navigator has the responsibility to check all aids available to confirm position.

Handle chart cards and memory cards with care.

- Keep cards away from direct sunlight, heat sources, and active gases.
- Keep cards away from water and chemicals.
- Keep the connector free of foreign material.
- Do not drop the cards.

### 2.1 Displaying Charts

#### 2.1.1 Inserting chart cards

1. Open the card slot cover at the left hand side of the display.
2. Insert a chart card label side left, arrow forward in the left-side card slot.

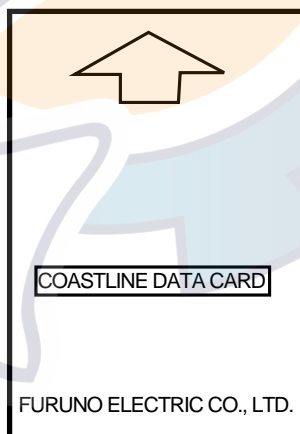

*Chart card*

3. Close the card slot cover.
4. Choose the combination display or the video plotter display.
5. Press the [+] or [-] key to display the chart.

**Note:** Chart cards may be inserted in the left slot; memory card in the right slot.

### 2.1.2 Chart icons

Chart icons are displayed to alert you to chart status.



Chart properly displayed.



Chart overenlarged.



Chart overenlarged or wrong chart.

*Chart icons*

### 2.1.3 Ejecting chart cards

Chart cards may be ejected with the radar turned on or off.

1. Press the EJECT button on the card slot.
3. Remove the chart card.

### 2.1.4 Troubleshooting

- Card inserted but no chart appears.
- Small island, etc. not filled in.
- Card is removed but chart remains on the screen.

To rectify the above cases, press the [+] or [-] key.

## 2.2 Showing/Hiding Chart Features

Chart features may be turned on/off as follows:

1. Press the [MENU] key to display the main menu.
2. Press the [1] key twice to show the Video Plot/AIS menu.
3. Press the [9] key twice to choose Coastline/Mark Disp.

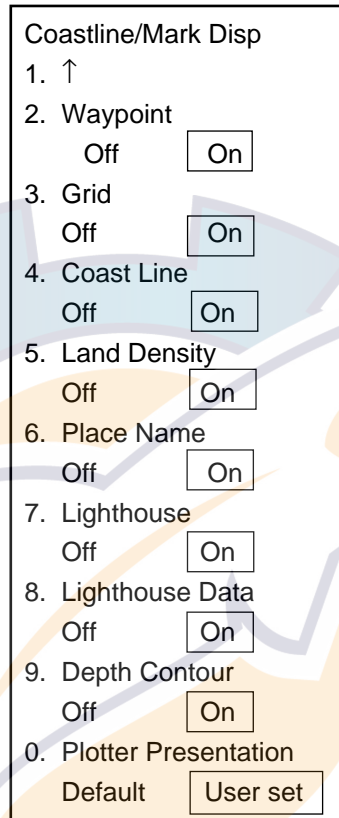

*Coastline/Mark Disp menu*

4. Press appropriate numeric key to choose both item and option.

Item	Description
Waypoint	Turns waypoint display on/off.
Grid	Turns grid on/off.
Coastline	Turns coastline on/off.
Land Density	Fills in (On) or hollows (Off) land. Note that land will be hollow if the wrong chart scale is used regardless of this setting.
Place Name	Turns geographic names on/off.
Lighthouse	Turns lighthouse icons on/off.
Lighthouse Data	Turns lighthouse viewing angle on/off. Viewing angle is shown as an arc extending from lighthouse position. Arc color, white or green, is the color of the lighthouse's beam. This feature is available on selected charts.
Depth Contour	Turns depth contour lines on/off.
Plotter Presentation	Chooses plotter screen settings; default or user setting. Default settings are as shown on the next page. Choose Default to erase marks, lines, L/L grid, etc., giving priority to the radar display.

5. Press the [ENTER/SELECT] key to register your selection.
6. Press the [MENU] key to escape.

Item	Setting
<b>Radar colors, brilliance and background</b>	
Background color	Black
Echo color	Yellow
<b>Color of chart elements</b>	
Land	Green
Grid	Green
Marks	Green
Contour	Green
<b>Chart information</b>	
Waypoints	ON
Grid	OFF
Coastline	ON
Land density	ON
Place name	OFF
Lighthouse	ON
Lighthouse data	ON
Depth contour	OFF
Target track	OFF
OS track	OFF
Marks	OFF

## 2.3 Position, Bearing Correction

### 2.3.1 Position correction

There may be some instances where the chart is not overlaid on the radar picture correctly. You can compensate for this error by applying an offset to chart position.

**Note 1:** A gyrocompass is required to get accurate correction.

**Note 2:** The radar display and coastline data use different calculation methods, thus they do not agree. Error is most prevalent in high longitudes.

1. Press the [MENU] key to open the main menu.
2. Press the [8] key twice to choose Mark.
3. Press the [5] key twice to choose Position Correction.

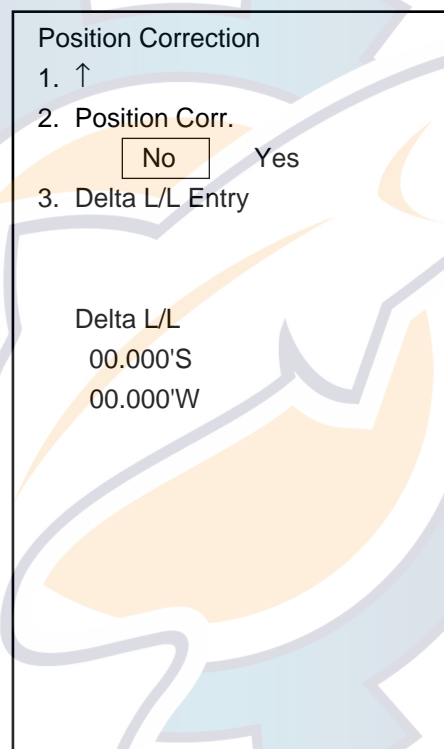

*Position Correction menu*

4. Press the [2] key to choose Yes, and press the [ENTER/SELECT] key.
5. Press the [ENTER/SELECT] key.
6. Press the [3] key to choose Delta L/L Entry.
7. Press the [ENTER/SELECT] key. The menu disappears and you are asked to operate the trackball to shift the chart.
8. Operate the trackball to shift the chart so that it is correctly aligned with the radar picture.
9. Press the [ENTER/SELECT] key.
10. Press the [MENU] key. The offset icon (☐) appears at the bottom of the display.

To remove the offset, choose No at step 4 in the above procedure.



### 2.3.2 Bearing correction

In some cases radar bearing may not match chart bearing. This can be corrected by offsetting bearing, automatically or manually. This feature is useful when no coastline is displayed; that is, vessel is in mid ocean. A magnetic compass is required.

1. Press [MENU], [8], [8], [5], [5] to display the Position Correction menu.
2. Press the [4] key to choose Manu., and press the [ENTER/SELECT] key.
3. Press the [5] key to choose Manual Entry, and press the [ENTER/SELECT] key. The menu disappears and the prompt "Rotate chart data by using VRM/EBL knob, and press ENT." appears.
4. As the prompt says, use the EBL or VRM knob to rotate chart data.
5. Press the [ENTER/SELECT] key. Control is returned to the Position Correction menu.
6. Press the [MENU] key to close the menu. The offset icon () appears at the bottom of the display.

To remove the bearing offset, choose Off at step 2 in the above procedure.

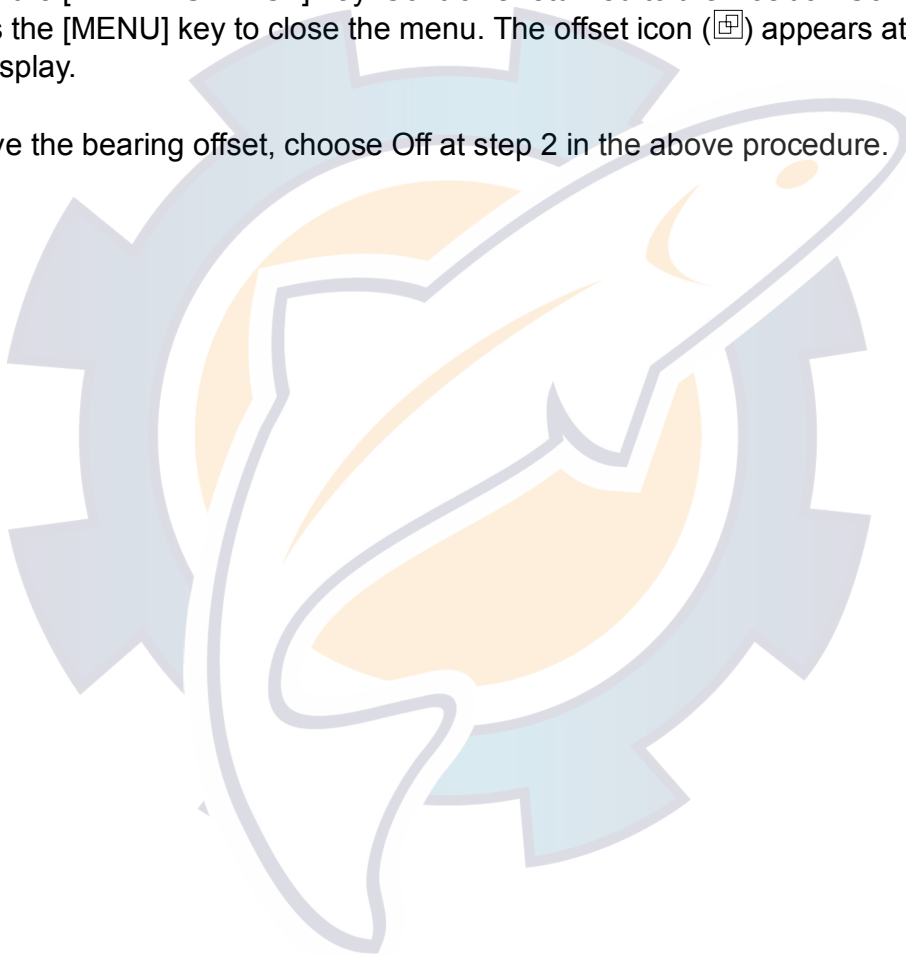

## 3. TRACK

### 3.1 Displaying Own Ship's Track

Own ship's track may be displayed as follows:

1. Press the [MENU] key.
2. Press the [1] key twice to show the Video Plot/AIS menu.
3. Press the [7] key twice to choose Plot Interval.

Plot Interval

1. ↑
2. Own Track  
Off  On
3. Plot Mode  
Time  Dist
4. Plot Time  
Time = 00M30S
5. Plot Distance  
Dist = 0.02nm
6. Save Own Track  
Yes  No
7. Other Track\*  
Off  On
8. Set Other Plot Intvl\*  
Time = 00M30S
9. Save Other Track\*  
Yes  No
0. Plot Color

\* Function available with ARP-17.

#### *Plot Interval menu*

4. Press the [2] key to choose On from the Own Track field.
5. Press the [ENTER/SELECT] key to register your selection and the [MENU] key to close the menu.

## 3.2 Stopping Plotting of Own Ship's Track

When your ship is at anchor or returning to port you probably will not need to plot (record) the track. You can stop plotting the track, to conserve the track memory, by actuating the "HOLD" function. The track is neither plotted nor saved, thereby conserving the track memory.

### 3.2.1 Stopping track plotting

1. Press [MENU], [1], [1], [7], [7] to display the Plot Interval menu.
2. Press the [6] key to choose No from the Save Own Track field.
3. Press the [ENTER/SELECT] key. The HOLD icon () appears at the bottom of the screen. (Video Plotter display only.)
4. Press the [MENU] key to finish.

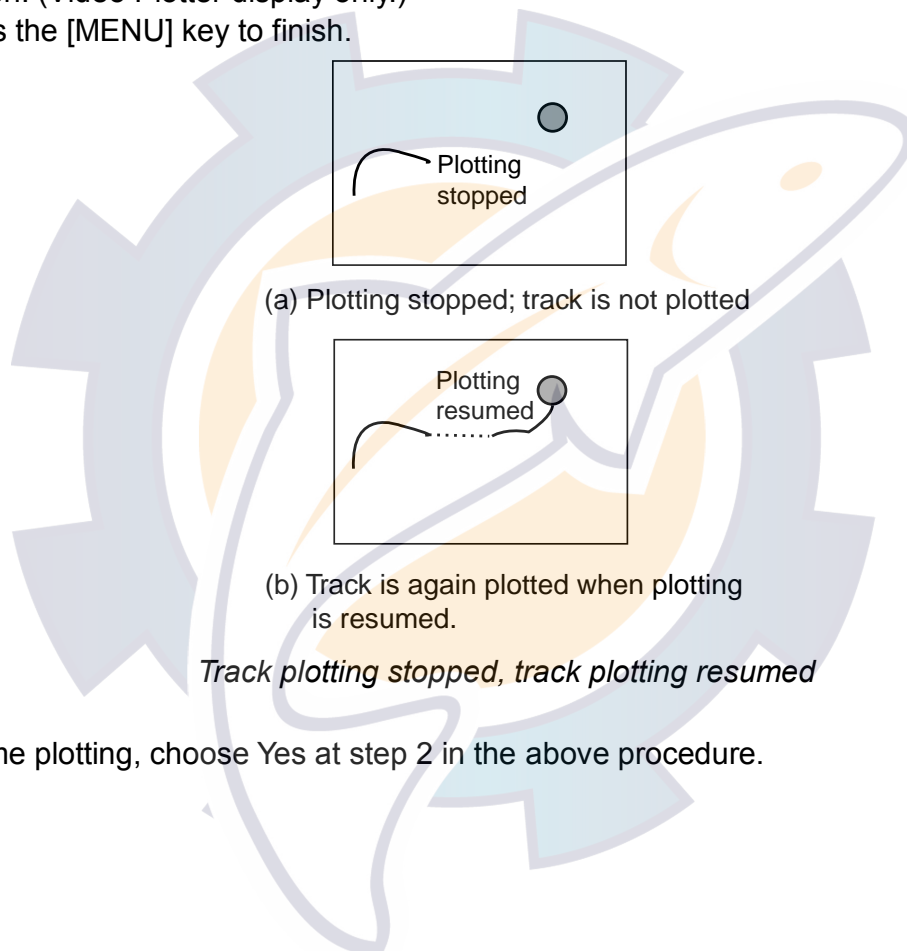

To resume plotting, choose Yes at step 2 in the above procedure.

### 3.3 Changing Own Ship's Plot Interval

The plot interval determines both how the track will be reconstructed on the display and the track storage time.

#### 3.3.1 How the track is drawn

The "quality" of the track displayed largely depends on the plot interval setting, smoothing rate, etc.

In drawing the track, first the ship's position fed from the navigation aid is stored into the radar's memory at an interval of time or distance selected by the operator. This interval of time or distance is called the "Plot Interval" and it is selected considering the ship's speed, the chart scale, etc. If a shorter interval is selected, a reconstructed course line is provided with better accuracy, but total storage time of the track is reduced.

Obviously there is a trade off between smooth reconstruction of the track and plot storage time: The shorter the interval the smoother the reconstruction but storage time is reduced. The following figure compares plot interval and track reconstruction.

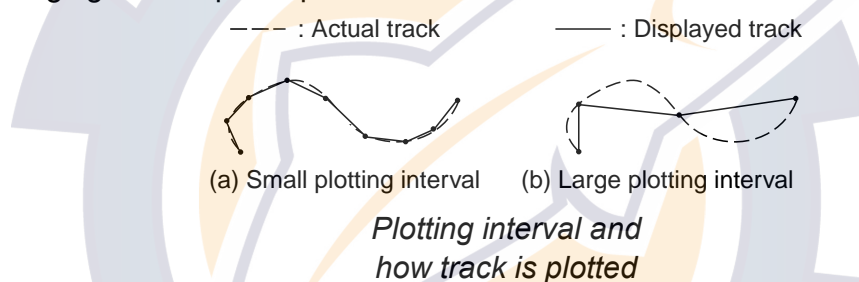

#### 3.3.2 Plot interval by time or distance

The plot interval can be selected by "Time" or "Distance". "Distance" is useful when the ship is anchored, since track is not plotted while the vessel is stationary.

#### 3.3.3 Setting plot interval

1. Press [MENU], [1], [1], [7], [7] to display the Plot Interval menu.
2. Press the [3] key to choose Time or Dist from the Plot Mode field.
3. Press the [ENTER/SELECT] key.
4. Press the [4] key if you selected Time at step 2; [5] key if you selected Dist.
5. Key in plotting interval with the numeric keys.
6. Press the [ENTER/SELECT] key to register your selection and the [MENU] key to close the menu.

### 3.4 Other Ship's Tracks and Plotting Interval

The tracks of up to 20 ships may be displayed when the Auto Tracking Aid ARP-17 is interfaced with the radar.

The plotting interval for other ships tracks can be set independently of that for own ship.

Also, plotting of other ships tracks may be suspended to conserve track memory.

1. Press [MENU], [1], [1], [7], [7] to display the Plot Interval menu.
2. Press the [7] key twice to choose On from Other Track.
3. Press the [ENTER/SELECT] key followed by the [MENU] key.



## 3.5 Erasing Own Ship's Track, Other Ship's Track

### 3.5.1 Erasing track by percentage

You may erase own ship's track and other ship's track by percentage points as follows:

1. Press the [MENU] key.
2. Press the [1] key twice to show the Video Plot/AIS menu.
3. Press the [0] key twice to choose AIS/Miscellaneous1.
4. Press the [3] key twice to display the Delete Memory menu.

Delete Memory

1. ↑

2. Mark  
 No  
 Display  
 All

3. Own Track  
 No  
 30%  
 50%  
 80%  
 All

4. Target Track  
 No  
 30%  
 50%  
 80%  
 All

5. Own Track Color All  
 R Y\* G\* C  
 M B W\*

6. Target Track Color All  
 R Y\* G\* C  
 M B W\*

Mark in use  
 3/20000

Own Track in use  
 17/20000

Target Track in use  
 0/20000

\* Not available on IMO-type radar.

#### *Delete memory menu*

5. Press the [3] key (Own Track) or [4] key (Target Track) to choose amount of track to erase. For example, 30% erases 30% of the track points stored in the track memory.
6. Press the [ENTER/SELECT] key.
7. Press the [ENTER/SELECT] key again followed by the [MENU] key.

### 3.5.2 Erasing track by color

Own ship's track and target tracks may be erased by color as follows:

1. Press [MENU], [1], [1], [0], [0], [3], [3] to show the Delete Memory menu.
2. Press the [5] key (Own Track Color All) or [6] (Target Track Color All) depending on your objective.
3. Press the [ENTER/SELECT] key.
4. Press the [ENTER/SELECT] key again followed by the [MENU] key.

### 3.6 Own Ship, Target Track Color

You may display own ship's track and target tracks in red, yellow\*, green\*, cyan, magenta, blue or white\*. as below. (\* = Not available on IMO-type radar.) The color currently chosen for each target is shown on the Plot Color menu.

1. Press the [MENU] key [1], [1], [7], [7] to open the Plot Interval menu.
2. Press the [0] key twice to choose Plot Color.

Plot Color	
1. ↑	
2. Own Ship Color	
R Y* G* C	
M B W*	
3. Target No. 01	
4. Target Plot Color	
R Y* G* C	
M B W*	
[Target Plot Color List]	
Target No.	Color
01	M
02	M
03	M
.	
.	
.	
20	M

\*: Not available on IMO-type radar.

*Plot color menu*

3. Do one of the following depending on your objective:

#### Own Ship Track Color

- a) Press the [2] key to choose Own Ship Color
- b) Press the [2] key again to choose color desired.

#### Target Track Color

- a) Press the [3] key to choose Target No.
- b) Key in target no. with the numeric keys and then press the [ENTER/SELECT] key.
- c) Press the [4] key to choose Target Plot Color.
- d) Press the [4] key again to choose color desired.

4. Press the [ENTER/SELECT] key.
5. Press the [MENU] key to close the menu.

## 4. MARKS, LINES

### 4.1 Displaying Marks, Lines

#### 4.1.1 Displaying marks, lines on the radar display

1. Press the [MENU] key.
2. Press the [8] key twice to show the Mark menu.

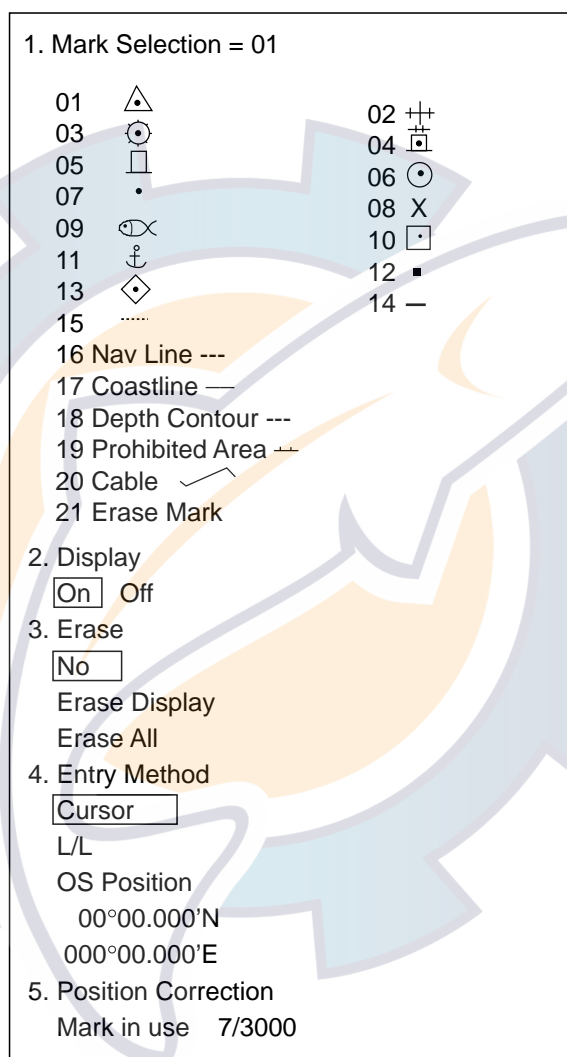

*Mark menu, radar display*

3. Press the [2] key to choose On.
4. Press the [ENTER/SELECT] key.
5. Press the [MENU] key to close the menu.

To turn off marks and lines, choose Off at step 3.





### 4.1.2 Displaying marks, lines on the combination and video plotter displays



1. Press the [MENU] key.
2. Press the [8] key twice to show the Mark menu.



Plotter Mark



1. Mark Selection = 01

01 Origin Mark 



02 OS Position 



03  04 

05  06 

07  08 

09  10 X

11  12 

13  14 

15  16 -

17 -----

18 Prohibited Area 

19 Cable 

20 Erase Mark

2. MOB

3. Display

On  Off

4. Mark Color\*

R Y G C

M B W

5. Position Correction

\* For the IMO-type radar the choices are RED, PNK (pink), PPL (purple) and ORG (orange).

*Mark menu, combination display*

3. Press the [3] key to choose On.
4. Press the [ENTER/SELECT] key.
5. Press the [MENU] key to close the menu.

To turn off marks and lines, choose Off at step 3.

## 4.2 Entering Marks, Lines

You can inscribe marks and lines on the display to denote important locations such as fishing spots, buoys, islands, etc.

### 4.2.1 Entering marks on the radar display

#### Choosing mark entry method

Marks may be entered on the radar display by cursor, latitude and longitude position and own ship's position.

1. Press the [MENU] key.
2. Press the [8] key twice to display the Mark menu.
3. Press the [1] key to choose Mark Selection.
4. Use the numeric keys to enter mark or line number desired.
5. Press the [ENTER/SELECT] key.
6. Press the [4] key to choose mark/line entry method desired; cursor, L/L, or own ship position.
7. Press the [ENTER/SELECT] key. Follow "Entering marks by cursor," "Entering marks by latitude and longitude position," or "Entering marks at own ship's position" depending on selection made at step 6.

#### Entering marks at cursor position

1. Choose Cursor at step 6 in "Choosing mark entry method" above.
2. Place cursor on location where to inscribe a mark.
3. Press the [MARK] key.
4. To enter a line, repeat steps 2 and 3.
5. Press the [MENU] key.

**Note:** To inscribe another line, press the [1] key, key in line number (type) shown on the Mark menu, press the [ENTER/SELECT] key, and the repeat steps 2 and 3. To inscribe more than two of the same type of line, after completing a line, press [1], [2] and [1] to choose Erase Mark, press the [ENTER/SELECT] key and then press [1] to choose line type. The, do steps 2 and 3 in "Entering marks at cursor position."

#### Entering marks by latitude and longitude position

1. Choose L/L at step 6 in "Choosing mark entry method" above.
2. Key in latitude and press the [ENTER/SELECT] key.
3. Key in longitude and press the [ENTER/SELECT] key.
4. Press the [MENU] key.

#### Entering marks at own ship's position

1. Choose OS Position at step 6 in "Choosing mark entry method" above.
2. Press the [MARK] key. A mark is placed at own ship's position.
3. Press the [MENU] key.

### 4.2.2 Entering marks on the combination, video plotter displays

Marks can be entered on the combination and video plotter displays by cursor or at own ship's position.

#### Choosing mark type

1. Press the [MENU] key.
2. Press the [8] key twice to display the Mark menu.
3. Press the [1] key to choose Mark Selection.
4. Use the numeric keys to enter mark or line number desired.
5. Press the [ENTER/SELECT] key.

**Note:** To inscribe a new line, press the [1] key, key in line number (type) shown on the Mark menu, press the [ENTER/SELECT] key, and the repeat steps 2 and 3. To inscribe more than two of the same type of line, after completing a line, press [1] [2] [1] to choose Erase Mark, press the [ENTER/SELECT] key and then press [1] to choose line type.

#### Entering marks at cursor position

1. Choose mark desired as described in "Choosing mark type" above.
2. Place cursor on location where to inscribe a mark.
3. Press the [MARK] key.
4. Press the [MENU] key.

#### Entering marks at own ship's position

1. Choose mark desired as described in "Choosing mark type" above
2. Press the [MARK] key.
3. Press the [MENU] key.

## 4.3 Erasing Marks, Lines

### 4.3.1 Erasing individual marks and lines

1. For mark, place the cursor on mark to erase. For line place the cursor on the point to erase.
2. Press the [CANCEL/CLEAR] key.

If the mark is not erased it may be superimposed on several marks. In this case, press the [CANCEL/CLEAR] key several times. To erase an entire line, all its points must be erased.

Individual origin marks and EPA plotting symbols are also erased in the same manner as marks and lines. For this reason you may wish to erase only marks or lines when they are superimposed on origin marks or plotting symbols. This can be done as follows:

1. Press the [MENU] key.
2. Press the [8] key twice to display the Mark menu.
3. Press the [1] key.
4. **For the radar display**, key in [2], [1].  
**For the video plotter or radar/plotter display**, key in [2], [0].
5. Press the [ENTER/SELECT] key.
6. Place cursor on mark or line point to erase.
7. Press the [MARK] key.
8. Press the [MENU] key to close the menu.

### 4.3.2 Erasing marks from the radar display

1. Press the [MENU] key.
2. Press the [8] key twice to display the Mark menu.
3. Press the [3] key to choose method of erasure:  
Erase Display: Erase all marks and lines currently displayed.  
Erase All: Erase all marks and lines including those stored in the memory (including currently displayed marks).
4. Press the [ENTER/SELECT] key.
5. Press the [ENTER/SELECT] key again to erase.
6. Press the [MENU] key to close the menu.

### 4.3.3 Erasing marks and lines on the combination, video plotter displays

Marks can be erased on the combination and video plotter displays individually or collectively.

1. Press the [MENU] key.
2. Press the [1] key twice to show the Video Plot/AIS menu.
3. Press the [0] key twice to choose AIS/Miscellaneous1.
4. Press the [3] key twice to choose Delete Memory.
5. Press the [2] key to choose mark erasure method; Display or All.
6. Press the [ENTER/SELECT] key.
7. Press the [ENTER/SELECT] key again to erase.
8. Press the [MENU] key to close the menu.

## 4.4 MOB Mark

The MOB (Man Overboard) mark denotes position of man overboard. This mark can only be inscribed on the combination and video plotter displays.

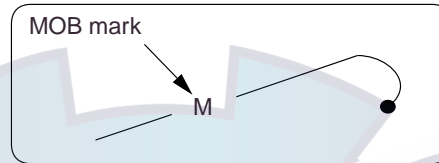
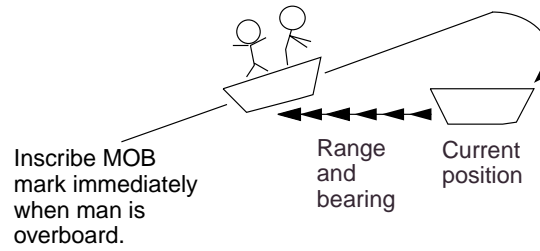

*MOB concept*

1. Press the [MENU] key.
2. Press the [8] key twice.
3. Press the [2] key to choose 2. MOB. The MOB mark ("M") is inscribed at own ship's position the moment the key is pressed.
4. Press the [MENU] key to close the menu.

A MOB mark can be erased by placing the cursor on it and pressing the [CANCEL/CLEAR] key.

## 4.5 Origin Mark

The origin mark ( $\oplus$ ) is mainly used to find the range and bearing between two targets on the radar/plotter and plotter displays.

1. Press the [MENU] key.
2. Press the [8] key twice to display the Mark menu.
3. Press the [1] key to choose Mark Selection.
4. Enter [0], [1] to choose Origin Mark .
5. Press the [ENTER/SELECT] key.
6. Place the cursor on target and press the [MENU] key.
7. Place the cursor on the other target.
8. Press the [MARK] key to close the menu.

The (orange) origin mark appears. Check cursor position display at the screen top to find range and bearing from the origin mark to own ship.

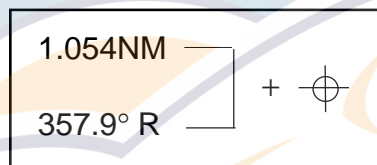

*Origin mark data*

To erase the origin mark, enter 01 at step 4.

## 4.6 Mark Color

Mark color can be selected as below. Note that the color of the origin mark (orange) cannot be changed.

1. With the video plotter mode selected, press [MENU], [8], [8].
2. Press the [4] key to choose mark color desired.
3. Press the [ENTER/SELECT] key to register your selection.
4. Press the [MENU] key to close the menu.



## 5. WAYPOINTS, ROUTES

In navigation terminology, a particular location is known as a “waypoint,” whether it be a starting point, a destination point or an intermediate point on a voyage.

### 5.1 Turning Waypoints On/Off

You may choose to turn all waypoints on or off, and the default setting is ON. Note however that when a route is displayed its waypoints are shown regardless of whether waypoints are turned on or off.

1. Press the [MENU] key.
2. Press the [1] key twice to display the Video Plot/AIS menu.
3. Press the [9] key twice to choose Coastline/Mark Disp menu.
4. Press the [2] key to choose On.
5. Press the [ENTER/SELECT] key followed by the [MENU] key.

### 5.2 Entering Waypoints

Waypoints may be entered on the video plotter, combination display, by the cursor, at own ship’s position, through the waypoint list. You can store 98 waypoints, numbered 01-98. Waypoints 00 and 99 are special waypoints. Waypoint 00 marks own ship’s position when destination is selected and waypoint 99 is for waypoint entered at the navigator (GPS, etc.)

#### 5.2.1 Entering waypoints at own ship’s position

1. Press the [MENU] key.
2. Press the [1] key twice to display the Video Plot/AIS menu.
3. Press the [4] key twice to choose Waypoint.

Enter Waypoint 1. ↑ 2. Cursor 3. OS Pos. 4. List 5. WPT No. 01
--

*Waypoint menu*

4. If you want to register the waypoint under a number different from what is shown below “WPT No.,” press the [5] key and key in desired waypoint number in two digits (01-98) and press the [ENTER/SELECT] key. (If you enter a number which already exists, “in use” appears.) If you do not care to change the waypoint number, go to step 5; the waypoint will be registered under the number shown below WPT No. Note that waypoint 00 or 99 cannot be entered - these are reserved for own ship position and external waypoint.



5. Press the [3] key (OS Pos) twice, and a waypoint mark with waypoint number inside is inscribed at own ship's position.
6. Press the [MENU] key to finish.

If there is no empty waypoint, a beep sounds and no waypoint can be entered. In this case erase unnecessary waypoints.

### 5.2.2 Entering waypoints at cursor position

1. Press [MENU], [1], [1], [4], [4].
2. If you want to register the waypoint under a number different from what is shown below "WPT No.," press the [5] key, key in desired waypoint number in two digits and then press the [ENTER/SELECT] key. If you do not care to change the waypoint number, go to step 3; the waypoint will be registered under the number shown below WPT No.
3. Place the cursor on the location desired for a waypoint.
4. Press the [2] key (Cursor) twice, and a waypoint mark with waypoint number inside is inscribed at the cursor location.
5. Press the [MENU] key to finish.

### 5.2.3 Entering waypoints by manual entry of latitude and longitude

1. Press [MENU], [1], [1], [4], [4].
2. Press the [4] key twice to choose List.

Data input cursor

(Waypoint List)			
No.	Comment		
1	00°00.000'N	000°00.000'E	ABCDEFGHIJK
2	00°00.000'N	000°00.000'E	9876543210
3	°-----'N	°-----'E	_____
4	°-----'N	°-----'E	_____
5	°-----'N	°-----'E	_____
6	°-----'N	°-----'E	_____
7	°-----'N	°-----'E	_____
8	°-----'N	°-----'E	_____
9	°-----'N	°-----'E	_____
10	°-----'N	°-----'E	_____
20	°-----'N	°-----'E	_____
99	°-----'N	°-----'E	_____

Enter Lat/Long.  
 N, E: + S, W: - Delete: CLR Enter: ENT  
 Escape: MENU

(Japanese characters appear here.)

A B C D E F G H I J K L M N O P Q R S T U V W X Y Z , - ! ? / & = # _ 1 2 3 4 5 6 7 8 9 0 a b c d e f g h i j k l m n o p q r s t u v w x y z	<b>OK</b>
---	-----------

Move cursor by using trackball and press ENT.

Character selection cursor Available characters

Waypoint list

3. Operate the trackball to place the cursor on an empty waypoint. You can scroll the list by placing the cursor at the bottom of the page.
4. Key in latitude and longitude with the numeric keys.  
**Note:** You can switch from North to South, East to West and vice versa with the [-] key. Do this before entering the data. An entire line of data can be cleared with the [CANCEL/CLEAR] key.)
5. If you want to enter a comment follow the procedure below. If not, go to step 6.
  - a) Confirm that the cursor is located in the Comments column. Choose alphanumeric character with the cursor. (Numerics can be directly entered with the numeric keys. A wrong character can be erased with the [CANCEL/CLEAR] key.)
  - b) Press the [ENTER/SELECT] key.
  - c) Repeat a) and b) to complete the comment.
  - d) Choose OK.
  - e) Press the [ENTER/SELECT] key.
6. Press the [ENTER/SELECT] key.
7. Press the [MENU] key to finish.

Waypoint number and waypoint mark are shown on the screen.

## 5.3 Waypoints

### 5.3.1 Deleting waypoints with the cursor

1. Use the trackball to select the waypoint to erase.
2. Press the [CANCEL/CLEAR] key.

### 5.3.2 Deleting waypoints through the waypoint list

1. Press [MENU], [1], [1], [4], [4], [4], [4] to display the waypoint list.
2. Use the trackball to choose the waypoint to erase.
3. Press the [CANCEL/CLEAR] key to delete waypoint.
4. Press the [ENTER/SELECT] key followed by the [MENU] key to finish.
5. Press the [MENU] key.

## 5.4 Creating Routes

In many cases a trip from one place to another involves several course changes, requiring a series of route points (waypoints) which you navigate to, one after another.

The sequence of waypoints leading to the ultimate destination is called a **route**. The RP-180 can automatically advance to the next waypoint on a route, so you do not have to change the destination waypoint repeatedly. The figure below shows an example of a route between two ports, involving six waypoints.

You can store up to 10 routes. A route may contain up to 30 waypoints.

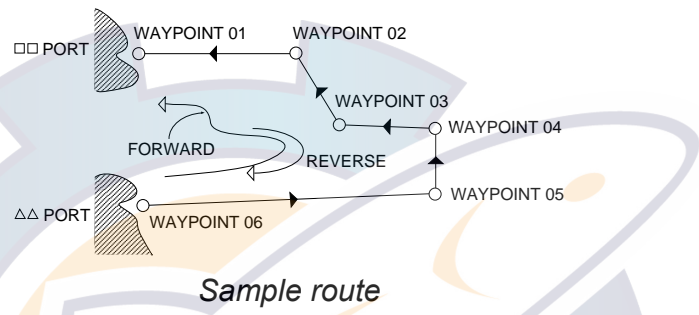

### 5.4.1 Creating routes with the cursor

1. Press the [MENU] key.
2. Press the [1] key twice to show the Video Plot/AIS menu.
3. Press the [5] key twice to choose Route.

Route					
1. Mode =		Cursor	WPT No.	List	
2. Speed for TTG =		10.0kt			
(Route List)					
▶ 1	30	YES	234.56 nm	345.6H	In use
2	5	YES	335.67 nm	455.6H	
3	3	YES	37.99 nm	19.9H	
⋮					
10	_ _	YES	_ _ _ _ nm	_ _ _ _ H	
Select mode and route no. by using trackball.					
Display: +    Not display: -					
Enter: ENT					
Delete: CLR					

*Route menu*

4. Press the [1] key to choose Cursor, and press the [ENTER/SELECT] key.
5. Press the [2] key to choose Speed for TTG.
6. Key in ship's speed with the numeric keys. (This allows for automatic calculation of time-to-go to waypoints.)
7. Press the [ENTER/SELECT] key.
8. Choose route number with the trackball.
9. Press the [ENTER/SELECT] key.

10. As the screen prompts, place the cursor where you want to have a waypoint for the route.
11. Press the [+] key. (To clear just-selected point, press the [-] key.)
12. Repeat steps 10 and 11 to complete the route.
13. Press the [ENTER/SELECT] key to register the route and the [MENU] key to close the menu.

### 5.4.2 Creating routes with waypoints

1. Press [MENU], [1], [1], [5], [5] to display the Route menu.
2. Press the [1] key to choose WPT no., and press the [ENTER/SELECT] key.
3. Press the [2] key to choose Speed for TTG.
4. Key in ship's speed with the numeric keys. (This allows for automatic calculation of time-to-go to waypoints.)
5. Press the [ENTER/SELECT] key.
6. Choose route number with the trackball.
7. Press the [ENTER/SELECT] key. The screen for selection of waypoint number appears.

Reg. Route (No. )			
WPT Nos. =	■	+	+
	-	+	+
	-	+	+
	-	+	+
(Waypoint List)			
No.	Comment		
↑			
▶ 1	34°44.135'N	135°10.856'E	ABCDEFGHIJK
2	34°40.236'N	135°09.211'E	9876543210
3	°-----'N	°-----'E	_____
4	°-----'N	°-----'E	_____
5	°-----'N	°-----'E	_____
9	°-----'N	°-----'E	_____
10	°-----'N	°-----'E	_____
20	°-----'N	°-----'E	_____
99	°-----'N	°-----'E	_____
Select WPT and press +key.			
To cancel, press -key.			
Repeat above steps and press ENT to conclude.			

#### *Screen for entering route by waypoints*

8. Choose waypoint number with the cursor and press the [+] key. (You may also enter waypoint number with the numeric keys in which case it is not necessary to press the [+] key.)
9. Repeat step 8 to complete the route.
10. Press the [ENTER/SELECT] key.
11. Press the [MENU] key to finish.

### 5.4.3 Creating routes from the route list

1. Press [MENU], [1], [1], [5], [5] to display the Route menu.
2. Press the [1] key to choose List, and press the [ENTER/SELECT] key.
3. Press the [2] key to choose Speed for TTG.
4. Key in ship's speed with the numeric keys. (This allows for automatic calculation of time-to-go to waypoints.)
5. Press the [ENTER/SELECT] key.
6. Choose route number with the trackball.
7. Press the [ENTER/SELECT] key. The screen for selection of route points appears.

Route (No. 01)				
	WPT	Skip	Distance	TTG
▶ 1	08	YES	0.00 nm	0.0H
2	11	NO	135.67 nm	75.7H
3	15	YES	185.07 nm	125.6H
4	18	NO	185.07 nm	125.6H
5	22	NO	234.60 nm	345.6H
6	--	NO	----- nm	----- H
7	--	NO	----- nm	----- H
8	--	NO	----- nm	----- H
9	--	NO	----- nm	----- H
10	--	NO	----- nm	----- H
30	--	NO	----- nm	----- H

Move cursor and enter WPT no.

Skip: - No Skip: +  
Delete: CLR Conclude: ENT Escape: MENU

#### Screen for making route

8. Locate the cursor where you want to enter a route point.
9. Key in waypoint number. (The buzzer sounds if you enter a waypoint which has not been registered.)
10. Press the [ENTER/SELECT] key.
11. Repeat steps 8-10 to complete the route.
12. Press the [MENU] key to finish.

## 5.5 Turning Route Display On/Off

You may choose to display (or not) a route as follows.

1. Press the [MENU] key.
2. Press the [1] key twice to show the Video Plot/AIS menu.
3. Press the [5] key twice to choose Route.
4. Choose route number with the trackball.
5. Press the [ + ] key to display the route; the [ - ] key to not display it.
6. Press the [ENTER/SELECT] key to register your selection and the [MENU] key to close the menu.



## 5.6 Deleting Route Waypoints

1. Press [MENU], [1], [1], [5], [5] to display the Route menu.
2. Press the [1] key twice to choose List.
3. Press the [ENTER/SELECT] key.
4. Use the trackball to choose route number.
5. Press the [ENTER/SELECT] key.
6. Use the trackball to choose route waypoint to delete.
7. Press the [CANCEL/CLEAR] key.
8. Press the [ENTER/SELECT] key. The route data changes to reflect deletion.
9. Press the [MENU] key to finish.

## 5.7 Deleting Routes

1. Press [MENU], [1], [1], [5], [5] to display the Route menu.
2. Choose route number with the trackball.
3. Press the [CANCEL/CLEAR] key.
4. Press the [ENTER/SELECT] key to delete the route.
5. Press the [MENU] key to finish.

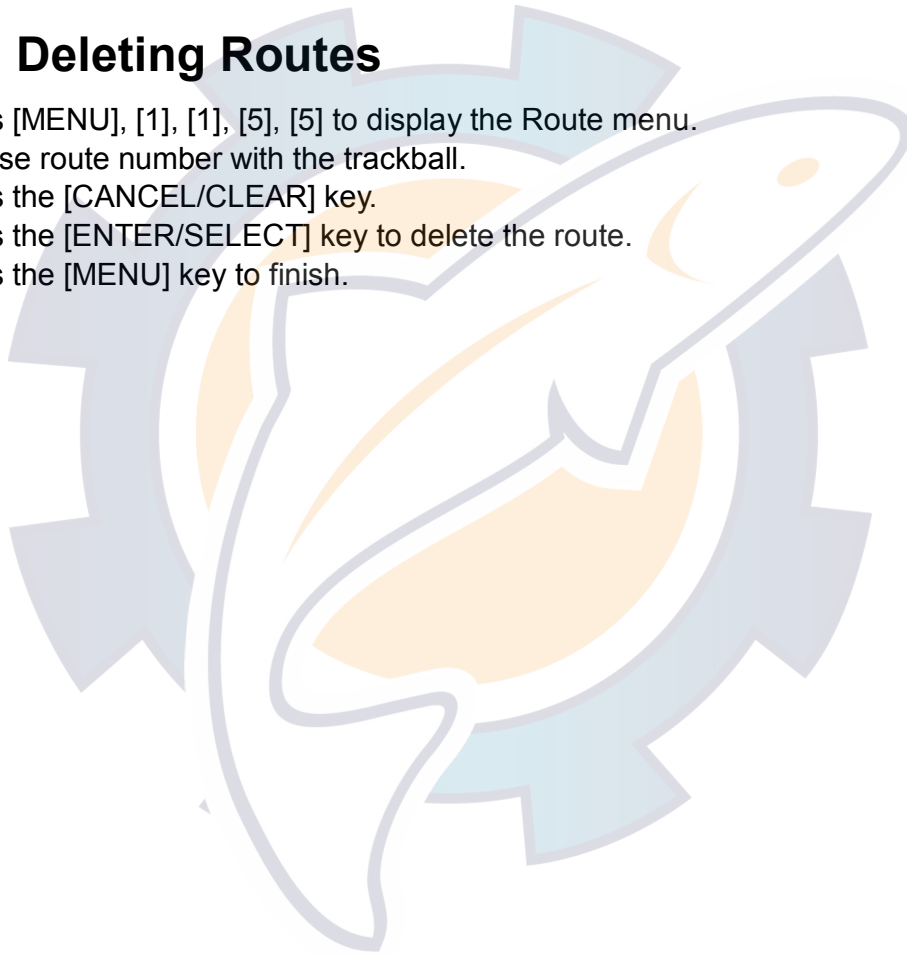

## 6. NAVIGATION

---

This section covers navigation. You can navigate by waypoint, cursor-selected point and route.

### 6.1 Navigation

#### 6.1.1 Navigating to a waypoint

1. Press the [MENU] key.
2. Press the [1] key twice to show the Video Plot/AIS menu.
3. Press the [6] key twice to choose Destination Set.

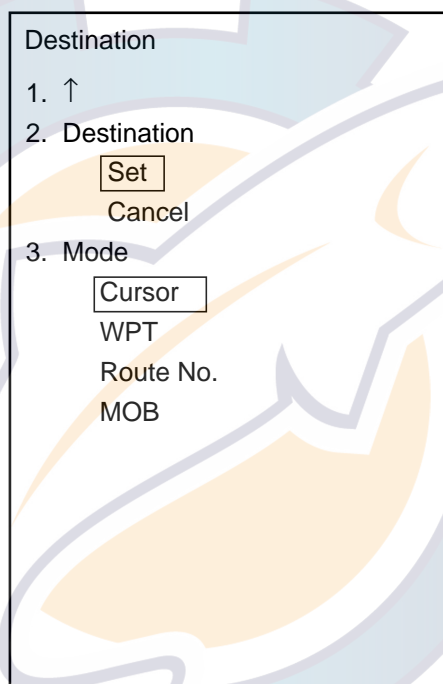

*Destination set menu*

4. Press the [3] key to choose Mode.
5. Press the [3] key again to choose WPT.



6. Press the [ENTER/SELECT] key.

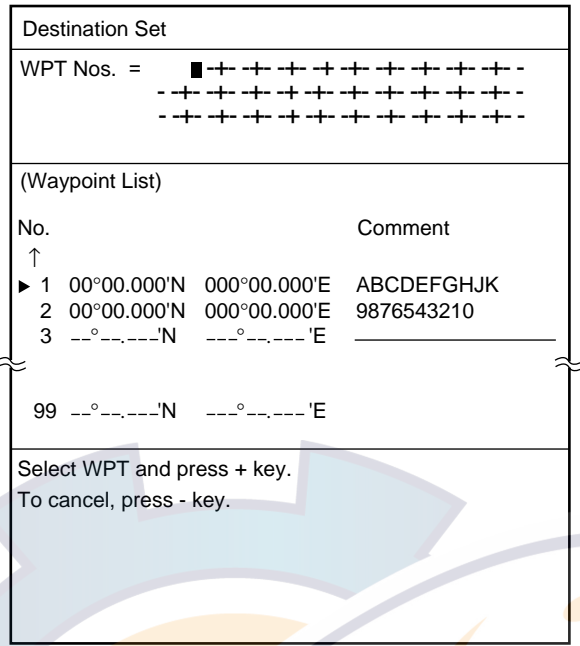

Screen for entry of destination waypoints

7. Use the trackball to choose a waypoint. (A waypoint may also be entered with the numeric keys, in which case omit step 7. If an unregistered waypoint number is entered the buzzer sounds to alert you.)
8. Press the [+] key to set waypoint. The [-] key can be used to cancel an entry.
9. If you want to navigate to more than one waypoint, repeat steps 6 and 7.
10. Press the [ENTER/SELECT] key. Current position is marked as “00” and a dashed line connects between it and all waypoints. This line shows the ideal course between waypoints.
11. Press the [MENU] key to finish.

**6.1.2 Navigating to cursor-selected point**

1. Press [MENU] [1], [1], [6], [6] to display the Destination menu.
2. Press the [3] key to choose Mode.
3. Press the [3] key to choose Cursor is selected and press the [ENTER/SELECT] key
4. As the screen prompts, use the trackball to place the cursor on location desired for destination and press the [+] key. (You may choose up to 30 points. To clear a selection, press [-].)
5. Press the [ENTER/SELECT] key. Current position is marked as “00” and a dashed line connects between it and all destination waypoints. This line shows the ideal course between waypoints.
6. Press the [MENU] key to finish.

### 6.1.3 Following a route

1. Press [MENU], [1], [1], [6], [6] to display the Destination menu. If a route is currently selected as destination, its number is shown at the top of the screen.
2. Press the [3] key to choose Route No. and press the [ENTER/SELECT] key.
3. Confirm that Route No. is selected.
4. Press the [ENTER/SELECT] key, and your display now looks something like the one below.

Destination Set				
1. Route nos. = --				
2. FWD/REV = <input type="text" value="Forward"/> Reverse				
(Route List)				
No.	Pts	Disp	Total	TTG
▶ 1	30	YES	234.56 nm	2345.6H
2	5	YES	14.50 nm	41.6H
3	--	YES	--- nm	---- H
...				
10	--	YES	--- nm	---- H
Select route and press +key. To cancel selection, press -key. Press ENT to conclude.				

*Screen for setting destination by route*

If a route is currently used for navigation, the route number appears in 1. Route nos. If not, "--" appears at that location.

5. Press the [2] key to choose the direction in which to traverse the route, Forward or Reverse.
6. Press the [ENTER/SELECT] key.
7. Use the trackball to select a route. (You also may enter route number with the numeric keys, in which case omit step 8. If an unregistered route number is entered the buzzer sounds to alert you.)
8. Press the [+] key. (You can cancel an entry with the [-] key).
9. Press the [ENTER/SELECT] key. Current position is marked as "00" and a dashed line connects between it and all route waypoints. This line shows the ideal course between waypoints.
10. Press the [MENU] key to finish.

### 6.1.4 Navigating to MOB position

MOB must be set beforehand.

1. Press [MENU] [1], [1], [6], [6] to display the Destination menu.
2. Press the [3] key to choose Mode and then MOB.
3. Press the [ENTER/SELECT] key. Current position is marked as "00" and a dashed line connects between it and MOB position. This line shows the ideal course between waypoints.

## 6.2 Cancelling Navigation

Once you arrive at your ultimate destination you probably won't need the destination waypoint. You can cancel it as follows:

1. Press [MENU], [1], [1], [6], [6] to display the Destination menu.
2. Press the [2] key to choose Cancel.
3. Press the [ENTER/SELECT] key followed by the [MENU] key.

**Note:** MOB destination can also be cancelled by placing the cursor on the MOB mark and pressing the [CANCEL/CLEAR] key. This can only be done when the MOB is not set as destination.

## 6.3 Skipping Route Waypoints

A route waypoint may be deselected temporarily from the route list. Using the following figure as an example, you would want to temporarily deselect route waypoints 04, since your ship is to change course at waypoint 05 and head to waypoint 03.

Route points cannot be skipped while following a route.

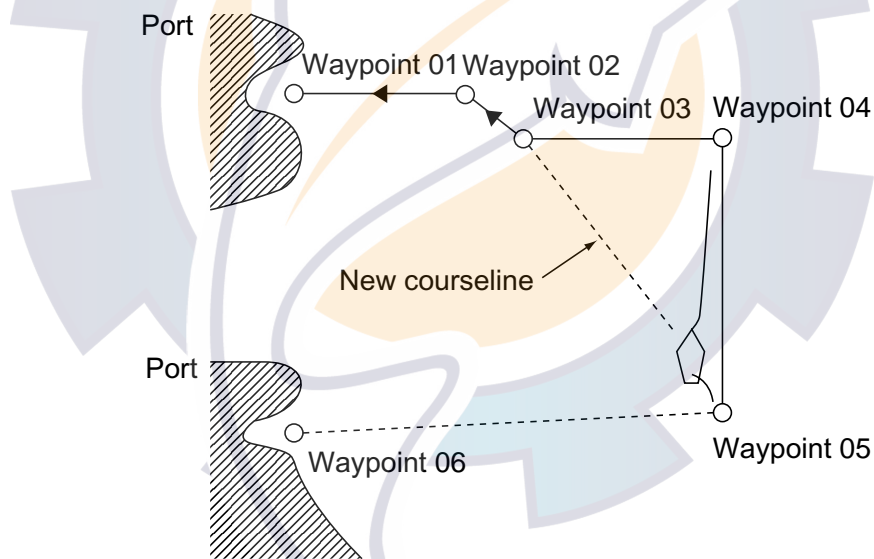

*Sample route in which waypoints are skipped*

1. Press [MENU], [1], [1], [5], [5] to display the Route menu.
2. Press the [1] key to choose List and then press the [ENTER/SELECT] key.
3. Use the trackball to choose route number.
4. Press the [ENTER/SELECT] key.

Display "Yes" to skip waypoint.

Route	(No. 01)				
	WPT	Skip	Distance	TTG	
▶ 1	08	YES	0.0 nm	0.0H	
2	11	NO	135.67 nm	75.6H	
3	15	YES	185.07 nm	125.6H	
4	18	NO	234.60 nm	234.6H	
5	22	NO	258.67 nm	345.6H	
6	--	NO	----- nm	----- H	
7	--	NO	----- nm	----- H	
8	--	NO	----- nm	----- H	
9	--	NO	----- nm	----- H	
10	--	NO	----- nm	----- H	
≈	30	NO	----- nm	----- H	
Move cursor and enter WPT no.					
Skip: - No skip: +					
Delete: CLR Conclude: ENT Escape: MENU					

*Route contents (route no. 1)*

5. Use the trackball to choose route point to skip with the cursor.
6. Press [-] key to display YES (in Skip column). The route data changes to reflect skipped waypoint.
7. Press the [ENTER/SELECT] key followed by the [MENU] key.

To restore a waypoint, press [+] at step 6 in the above procedure.

*(This page intentionally left blank.)*



# 7. ALARMS

There are four conditions which releases visual and audible alarms: Arrival alarm, Anchor watch alarm, XTE (Cross-track Error) alarm and Border alarm. When an alarm setting is violated the audible alarm sounds and the alarm icon (🔊) appears at the bottom right-hand corner of the display. To silence the buzzer, press the [AUDIO OFF] key.

## 7.1 Arrival Alarm, Anchor Watch Alarm

The **Arrival alarm** alerts you when own ship nears a waypoint by the distance set. The **Anchor Watch alarm** sounds when own ship is moving when it should be at rest.

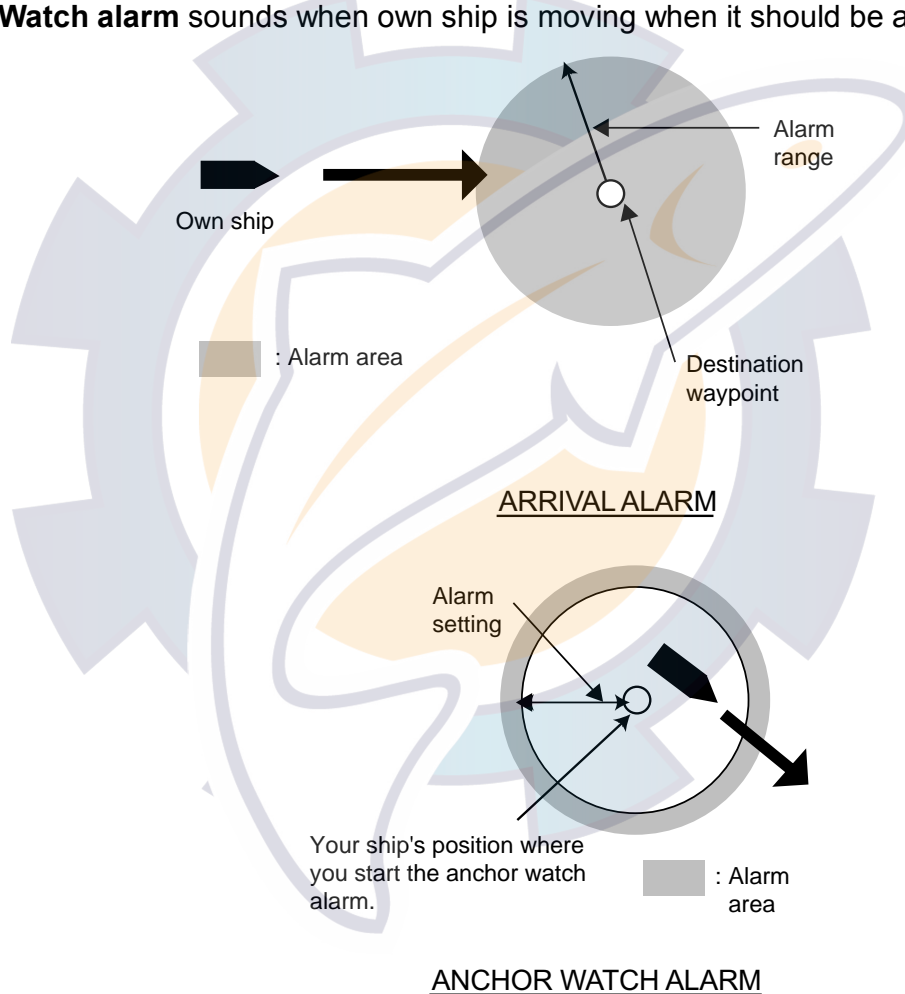

*Arrival alarm, anchor watch alarm concept*

Before setting the arrival or anchor watch alarm, set a destination waypoint. For the anchor watch alarm the destination should be own ship position.

1. Press the [MENU] key.
2. Press the [1] key twice to show the Video Plot/AIS menu.
3. Press the [0] key twice to choose Miscellaneous.
4. Press the [2] key twice to choose Alarm Set.

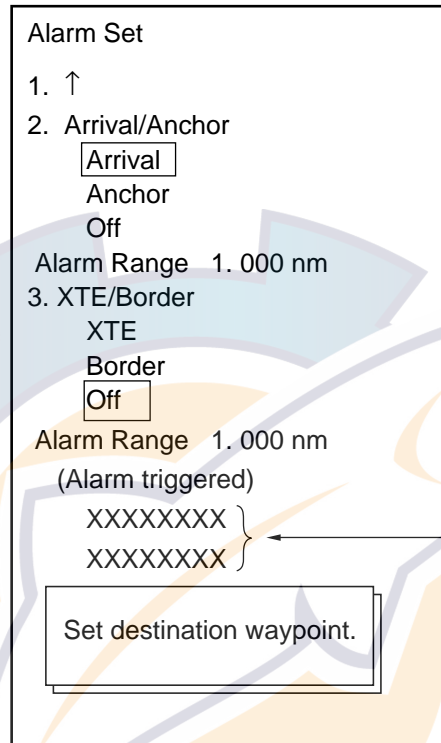

Shows which alarm is sounding.

*Alarm Set menu*

5. Press the [2] key to choose Arrival or Anchor.
6. Press the [ENTER/SELECT] key.
7. Key in alarm range (0.001-9.999). (To cancel input, press the [CANCEL/CLEAR] key.)
8. Press the [ENTER/SELECT] key.
9. Press the [MENU] key to finish.

To disable the Anchor watch alarm or Arrival alarm, choose Off at step 5 in the above procedure.

## 7.2 XTE Alarm, Border Alarm

The **XTE (cross-track error) alarm** warns you when own ship is off its intended course. The **Border alarm** alerts you when own ship is nearing an area which you do not want to approach.

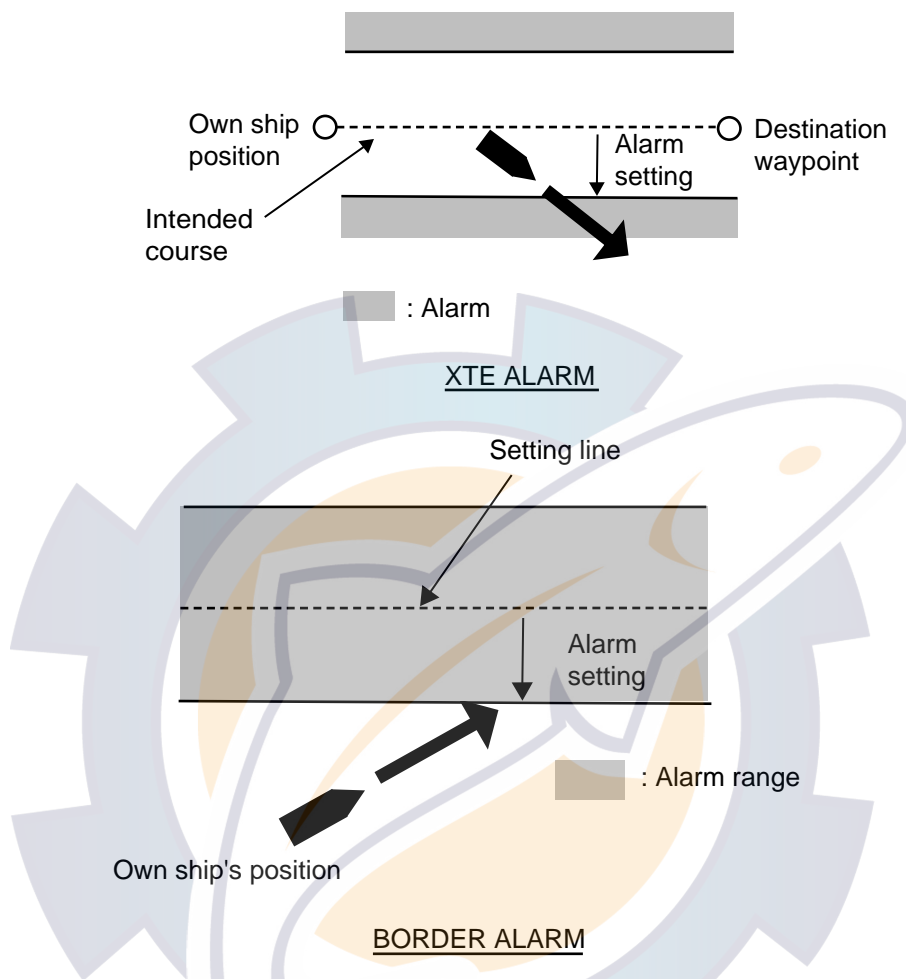

### *XTE alarm, border alarm concept*

1. Press [MENU], [1], [1], [0], [0], [2], [2] to display the Alarm Set menu.
2. Press the [3] key to choose XTE or Border.
3. Press the [ENTER/SELECT] key.
4. Key in alarm range (0.001-9.999). (To cancel input, press the [CANCEL/CLEAR] key.)
5. Press the [ENTER/SELECT] key.
6. Press the [MENU] key to finish.

To disable the XTE alarm or Border alarm, choose Off at step 2 in the above procedure.



*This page intentionally left blank.)*



## 8. MEMORY CARD OPERATIONS

---

### 8.1 Formatting Memory Cards

Before you can save information to a memory card you must prepare its surface by formatting it. Formatting is a routine procedure you must perform on new cards before you can use them with this unit. You have to initialize them only once. You can format cards you've used before, however, in which case all prior information on them is erased.

1. Press the [MENU] key.
2. Press the [1] key twice.
3. Press the [8] key twice to open the Memory Card menu.

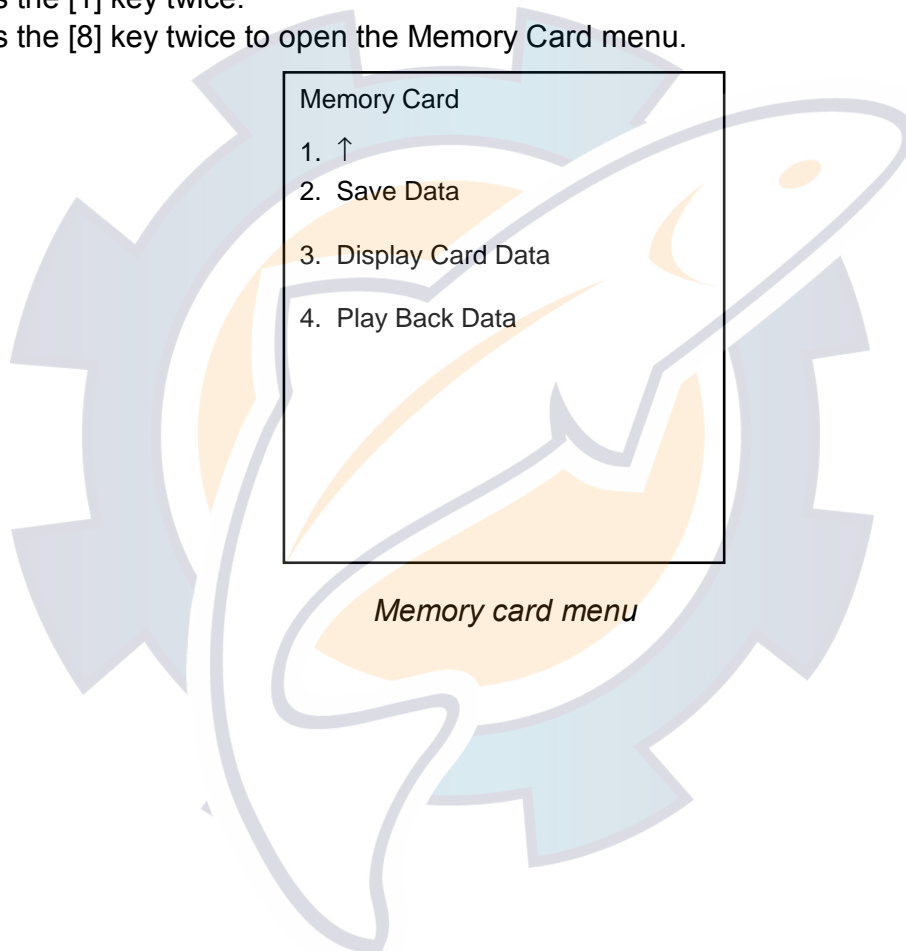

4. Press the [2] key twice to open the Save Data menu.

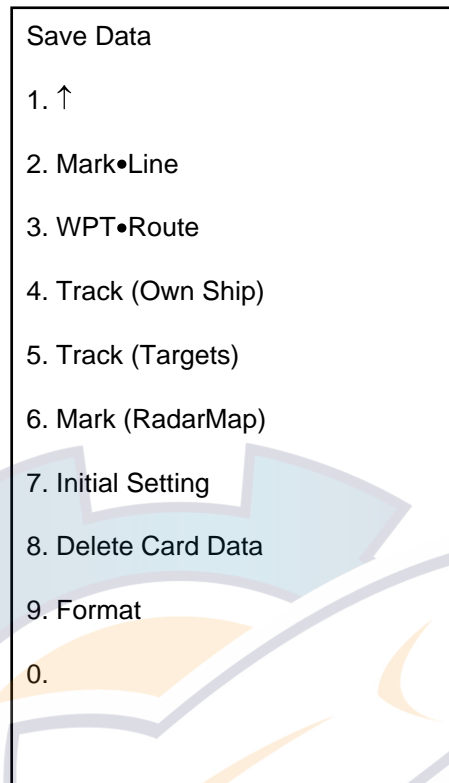

*Save Data menu*

5. Press the [9] key twice to choose Format.
6. As the screen prompts, press the [ENTER/SELECT] key to format the card. "Formatting" appears while the card is being formatted, and "Formatting completed" when formatting is completed.
7. Press the [MENU] key to finish.

## 8.2 Saving Screen Contents to Memory Card

The memory cannot store track and marks indefinitely. For this reason, important track and marks should be saved to a memory card. A memory card can store 50 files. For 6,000 track points, for example, the card can store eight files (card memory capacity: 512 KB).

1. Insert a formatted memory card in the card slot.
2. Press [MENU], [1], [1], [8], [8] to display the Memory Card menu.
3. Press the [2] key twice to display the Save Data menu.
4. Choose item to save by pressing appropriate numeric key twice: [2], marks/lines; [3], routes/waypoints; [4], own ship's track; [5], other ship's tracks; [6], marks, or [7], initial settings.

Mark•Line	(L SLOT)	Date	Pts.
▶ 00	New File		
01			
TOTAL NO. OF FILES = 1			
Data input cursor			
Move cursor by using trackball and press ENT. Escape : MENU			
☐ (Japanese characters appear here.)			
A B C D E F G H I J K L M N O P Q R S T U V W X Y Z , - ! ? / & = # _ 1 2 3 4 5 6 7 8 9 0 a b c d e f g h i j k l m n o p q r s t u v w x y z (OK)			
Move cursor by using trackball and press ENT.			

### *Mark•Line Save menu*

5. Operate the trackball to choose "New file" and press the [ENTER/SELECT] key.

8. MEMORY CARD OPERATIONS

6. Assign a file name as below. A file name may contain 32 alphanumeric characters. For example, assign the file name FURUNO1.
  - (a) Choose the character "F" with the trackball.
  - (b) Press the [ENTER/SELECT] key. (You can change a wrong character by choosing it with the trackball and the entering correct character. You may cancel an entire line of data with the [CANCEL/CLEAR] key.)
  - (c) Choose the character "U" with the trackball and press the [ENTER/SELECT] key.
  - (d) Enter the remaining characters.
  - (e) Choose OK.
7. Press the [ENTER/SELECT] key. "Recording" appears while data is being recorded.
8. Press the [MENU] key to finish.

**Write protect tab**

The write protect tab on a memory card prevents writing over information stored on the card. Slide the tab rightward to write protect a memory card.

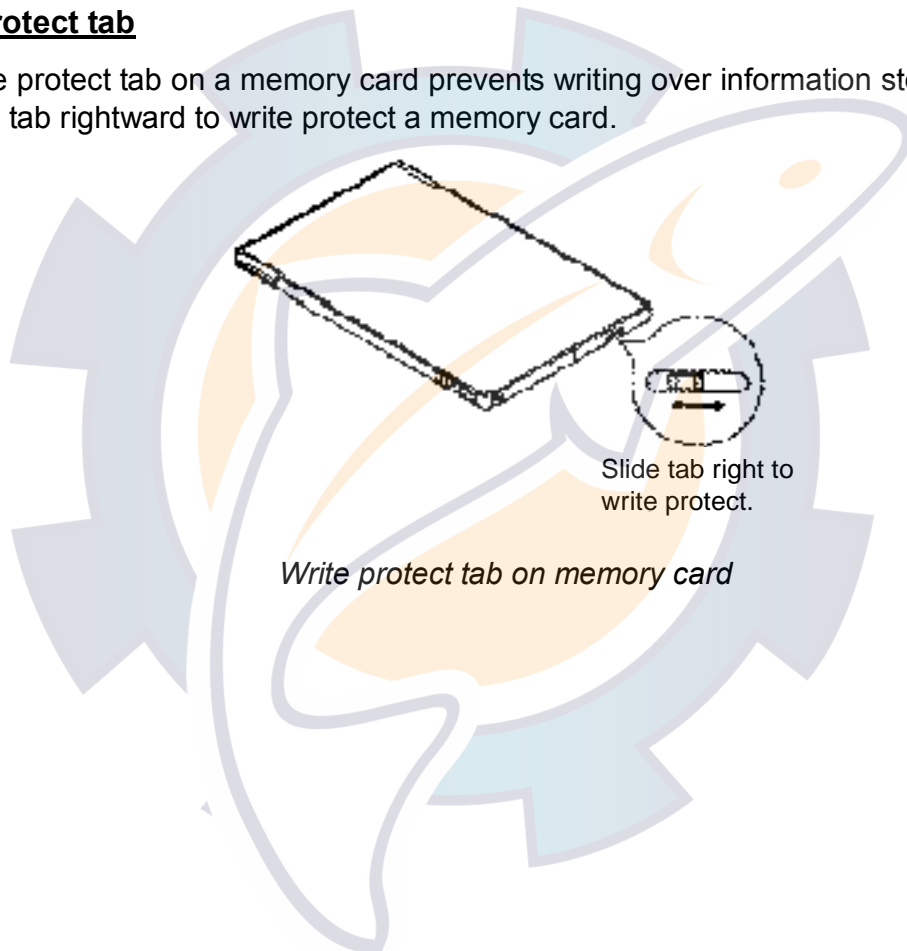

Slide tab right to write protect.

*Write protect tab on memory card*

### 8.3 Displaying Memory Card Contents on the Display

Up to eight files may be played back on the radar display.

1. Insert memory card in card slot.
2. Press [MENU], [1], [1], [8], [8] to display the Memory Card menu.
3. Press the [3] key twice to choose Display Card Data.

Display Card Data		(L SLOT)		Disp
▶01	1234567890123456	(2004-03-27)		YES
	7890123456789012	MARK	44	NO
02	Aimee	(2004-03-27)		NO
		WPT	13	
03				
10				
(TOTAL NO. OF FILES = 2)				
Move cursor : Trackball				
Display : +				
Not display : -				
Register : ENT				
Escape : MENU				

#### *Display Card Data menu*

4. Operate the trackball to choose the file to display.
5. Press the [+] key to display Yes; or [-] to display No.
6. Press the [ENTER/SELECT] key followed by the [MENU] key.

## 8.4 Playing Back Memory Cards

Memory card contents can be played back on the screen. This feature is useful for editing and copying card contents.

1. Insert memory card in card slot.
2. Press [MENU], [1], [1], [8], [8] to display the Memory Card menu.
3. Press the [4] key twice to choose Play Back Data.

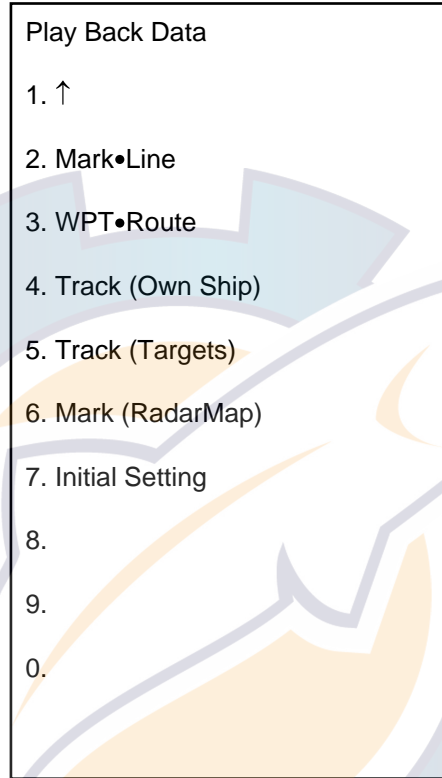

*Play Back Data menu*

4. Press appropriate numeric key among 2-7 to choose data to play back.
5. Press the [ENTER/SELECT] key. File list appears.
6. Operate the trackball to choose file to play back.
7. Press the [ENTER/SELECT] key followed by the [MENU] key.

## 8.5 Erasing Files from Memory Cards

You can erase unnecessary files as follows:

1. Press [MENU], [1], [1], [8], [8] to display the Memory Card menu.
2. Press the [2] key twice to choose Save Data.
3. Press the [8] key twice to choose Delete Card Data.

Delete Card Data		(L SLOT)
	Date	Pts.
▶01 1234567890123456	(2004-04-10)	1234
	MARK	
02 Aimee	(2004-03-27)	1234
	WPT	
03		
04		
05		
06		
10		
(TOTAL NO. OF FILES = 02)		
Move cursor by using trackball and press ENT.		
Escape: MENU		

### *Delete card data menu*

4. Operate the trackball to choose file to erase.
5. Press the [ENTER/SELECT] key.
6. Press the [ENTER/SELECT] key again.
7. Press the [MENU] key to close the menu.



*(This page intentionally left blank.)*



## 9. OTHER FUNCTIONS

### 9.1 Entering Ship's Position Manually

Ship's speed is normally input by the navigator connected to the radar. If the navigator fails enter ship's position manually as follows:

1. Press the [MENU] key.
2. Press the [1] key twice to show the Video Plot/AIS menu.
3. Press the [0] key twice to choose AIS/Miscellaneous1.
4. Press the [7] key twice to choose Miscellaneous2.

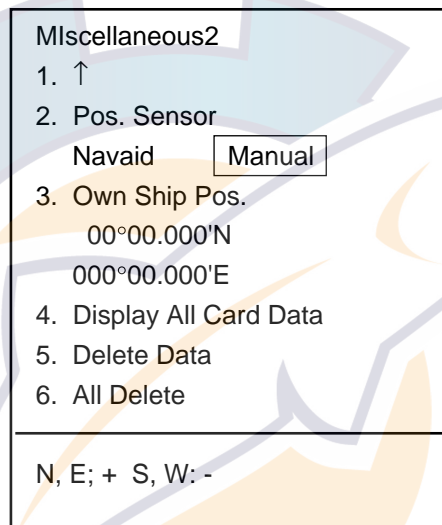

*Miscellaneous2 menu*

5. Press the [3] key to choose Own Ship Pos.
6. Key in latitude position of ship. (Use the [-] key to switch latitude coordinate from North to South; [+] from South to North.)
7. Press the [ENTER/SELECT] key.
8. Key in longitude position of ship. (Use the [-] to switch latitude coordinate from East to West; [+] from West to East.)
9. Press the [ENTER/SELECT] key.
10. Press the [2] key to choose Manual.
11. Press the [ENTER/SELECT] key to register your selection.
12. Press the [MENU] key to finish.

## 9.2 Smoothing

Own ship's track may be traced on the screen with a crooked line even though the ship is running straight. This is due to navaid signal variation, and can be compensated by adjusting the smoothing factor. A smoothing setting between 00 and 15 is available. The higher the figure the more the track is smoothed however too high a setting slows response time to speed and course changes.

1. Press [MENU], [1], [1], [0], [0], [5], [5] to display the Initial Setting menu.

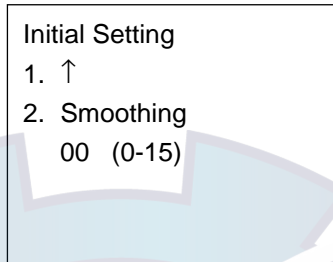

*Initial setting menu*

2. Press the [2] key to choose Smoothing.
3. Key in smoothing factor in two digits.
4. Press the [ENTER/SELECT] key to register your selection.
5. Press the [MENU] key to finish.

## 9.3 Viewing Chart Card Contents

You may display the contents of the chart card on the smallest range scale as follows:

1. Press the [MENU] key.
2. Press the [1] key twice to show the Video Plot/AIS menu.
3. Press the [0] key twice to choose AIS/Miscellaneous1.
4. Press the [7] key twice to choose Miscellaneous2.
5. Press the [4] key twice to choose Display All Card Data.
6. Press the [ENTER/SELECT] key followed by [MENU] key to finish.

## 9.4 Adjusting Brilliance

### 9.4.1 Chart features

You may adjust the brilliance of chart features as follows:

1. Press [MENU], [9], [9], [9], [9] to display page 2 of the Brill menu.

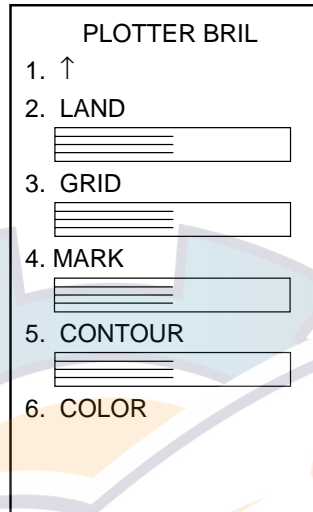

*Brill menu, page 2*

2. Press appropriate numeric key among 2-5 to choose item to change brilliance.
3. Use the VRM control to adjust brilliance. Watch the bar graph to judge brilliance level. The range of the bar graph is 10% to 100%.
4. Press the [ENTER/SELECT] key to register and the [MENU] key to close the menu.

### 9.4.2 Markers

The brilliance of tracks (own and other ships'), AIS symbols, marks and lines may be adjust as follows:

1. Press [MENU], [9], [9], [6] to choose MARK.
2. Use the VRM control to adjust brilliance.
3. Press the [ENTER/SELECT] key.
4. Press the [MENU] key to finish.

## 9.5 Clearing All Data

You may clear all track, marks, waypoints and routes to start afresh.

1. Press the [MENU] key.
2. Press the [1] key twice to show the Video Plot/AIS menu.
3. Press the [0] key twice to choose AIS/Miscellaneous1.
4. Press the [7] key twice to choose Miscellaneous2.
5. Press the [5] key twice to choose Delete Data.
6. Press the [ENTER/SELECT] key..
7. Press the [MENU] key to finish.

## 9.6 Restoring Default Settings

1. Press the [MENU] key.
2. Press the [1] key twice to show the Video Plot/AIS menu.
3. Press the [0] key twice to choose AIS/Miscellaneous1.
4. Press the [7] key twice to choose Miscellaneous2.
5. Press the [6] key twice to choose All Delete.
6. Press the [ENTER/SELECT] key.
7. Press the [ENTER/SELECT] key again.
8. Reset the power.

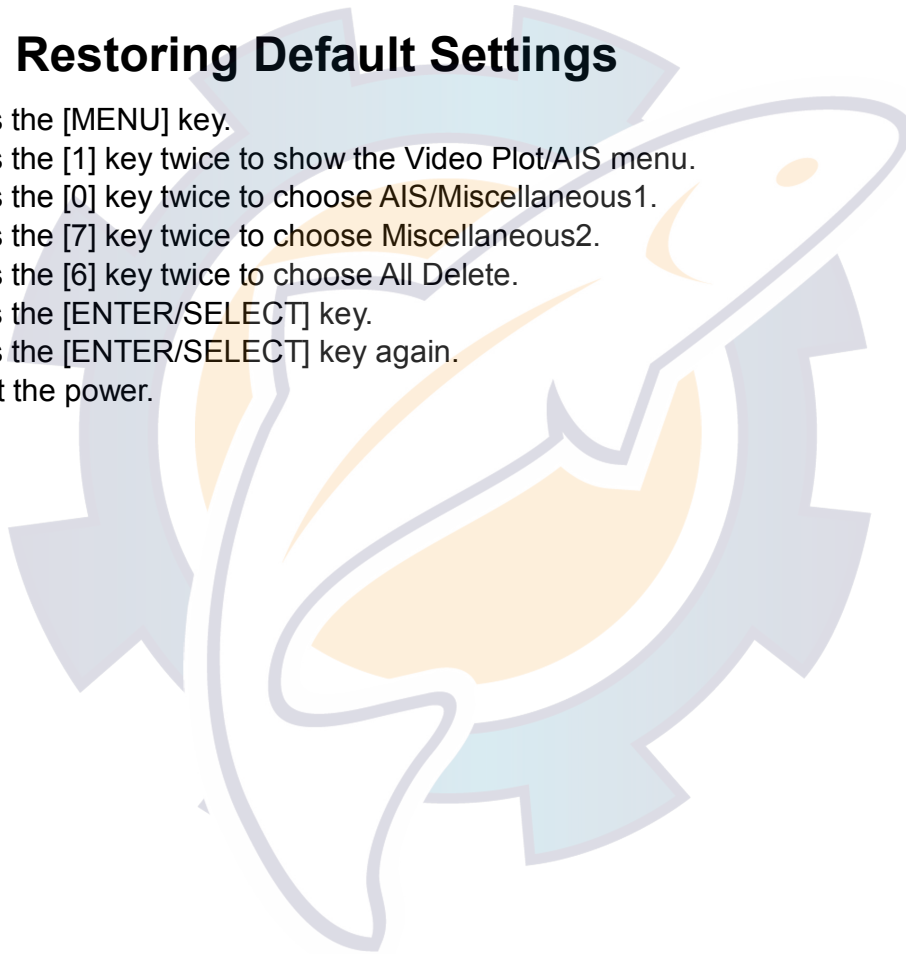

## 9.7 Marker Colors on Chart Cards

You may change the color of grid, marks, land and depth contour as follows.

1. Press [MENU], [9], [9], [9], [9], [6], [6] to display the Plotter Color menu.

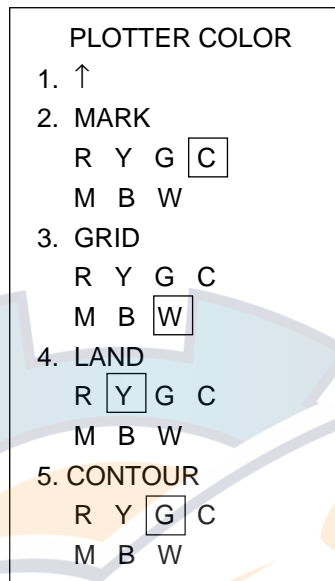

*Plotter Color menu*

2. Press appropriate numeric key to choose marker and color desired. R, Red; Y, Yellow; G, Green; C, Cyan (Light-blue); M, Magenta; B, Blue, W, White.
3. Press the [ENTER/SELECT] key to register your selection and the [MENU] key to close the menu.

## 9.8 Apportioning the Memory

The memory holds a total of 40,000 points of tracks and marks, and the default memory apportion is 20,000 points each of tracks and marks. However, you may change that setting to suit your operating needs as follows:

**Note:** All track and marks are erased when the memory is reapportioned.

1. Press the [MENU] key.
2. Press the [1] key twice to show the Video Plot/AIS menu.
3. Press the [0] key twice to choose AIS/Miscellaneous1.
5. Press the [4] key twice to choose Apportion Memory.

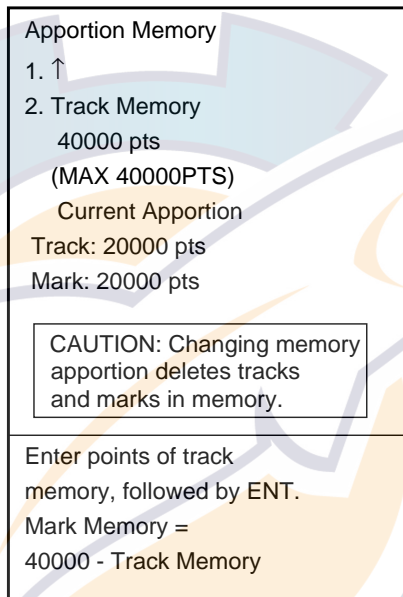

5. Press the [2] key to choose Track Memory.
6. Enter the memory capacity desired for track points.
7. Press the [ENTER/SELECT] key.
8. Press the [ENTER/SELECT] key again.
9. Press the [MENU] key.

## 10. AIS

---

The AIS (Automatic Identification System) feature automatically provides navigation data on AIS-equipped ships.



### WARNING

Confirm compass reading on radar and gyrocompass readout when the bearing of AIS targets do not match that of corresponding radar targets.

### 10.1 Changing Function of [F2] Key to AIS

If desired the [F2] can be programmed to open the AIS(1) menu.

1. Press the [STBY/TX] key to set the radar in stand-by.
2. Press the [MENU] key.
3. Press the [6] key twice to open the [FUNC] menu.
4. Press the [7] key twice to open the [F2 SET] menu.
5. Rotate the VRM control to choose "32.\* AIS(1) MENU" (\*: 31 for IMO-type radar).
6. Press the [ENTER/SELECT] key to register the function of the [F2] key as AIS.
7. Press the [MENU] key to close the menu.

**Note:** The [F2] key can also be assigned to display basic AIS data (33.\* AIS DATA; \*: 32 for IMO-type radar). For further details see paragraph 10.5.1.



## 10.2 Turning AIS Feature On/Off

1. Press the [F2] key to open the AIS(1) menu.

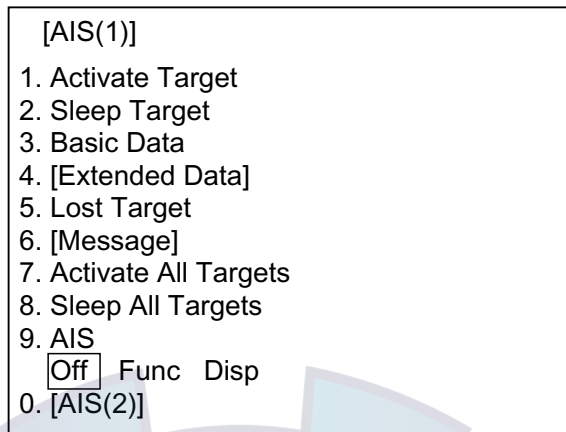

AIS(1) menu

2. Press the [9] key to choose Off, Func, or Disp as appropriate.
  - Off: All AIS symbols erased and the AIS function is deactivated.
  - Func: All AIS symbols are erased, but all other AIS functions (collision watch, etc.) are remain active.
  - Disp: AI targets received from the AIS transponder are displayed with symbols, and all AIS functions (collision watch, etc.) are active.
3. Press the [ENTER/SELECT] key. "AIS:F" (FUNCTION) or "AIS:D" (DISPLAY) appears at the top right hand corner on the display.
4. Press the [MENU] key to close the menu.

When DISP is selected, AIS-equipped ships are marked on the display at their current position with the appropriate AIS symbol as shown below.



AIS symbols

- Note 1:** For the setting Func or Off, all AIS symbols are erased from the screen, however AIS functions continue internally. The setting Disp will show all AIS targets on the screen.
- Note 2:** AIS symbols are momentarily erased after the screen is redrawn when bow direction is changed in the Head-up mode.
- Note 3:** The AIS(1) menu can also be opened by using the [MENU] key. The keying sequence is [MENU], [1], [1], [0], [0], [8], [8].
- Note 4:** AIS is automatically turned off under any of the the conditions noted below and, if the condition continues, the function "Disp" or "Func" cannot be selected.
  - a) EPFS or gyro alarm generated.
  - b) Manual ship' speed is used. (See 9.1. IMO-type radar only.)
  - c) Receiving DTM sentence and it does not contain WGS-84. (IMO-type radar only)

## 10.3 Activating Targets

1. Use the trackball to place the cursor on the sleeping AIS target (indicates only the presence of a vessel equipped with AIS in a certain location) you wish to activate; that is, know more about a vessel's motion.
2. Press the [F2] key to open the AIS(1) menu.
3. Press the [1] key (Activate Target) to activate the target. The activated AIS target symbol is superimposed on the radar echo as below.

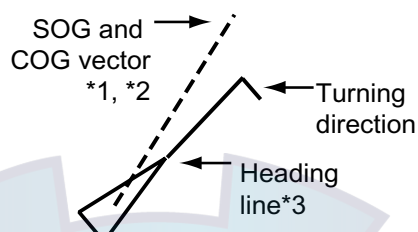

*Activated target*

\*1 = Length adjustable on the PLOT menu 1 with 4. VECTOR TIME.

\*2 = Vector shows STW (speed thru water) and CSE (course) when water tracking mode is selected at the radar.

\*3 = If there is no heading data, the line points in direction of COG.

4. Press the [MENU] key to close the menu.

### Dangerous target

When an activated AIS target violates the CPA/TCPA alarm setting set on the PLOT menu 1 its symbol changes to the dangerous target symbol (red and flashing) and the indication "A-CLSN" appears. Press the [AUDIO OFF] key to acknowledge the CPA/TCPA alarm. The audio alarm is silenced and the symbol stops flashing. Take appropriate action to avoid collision.

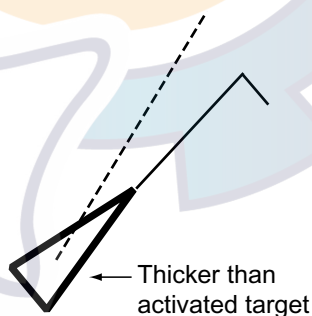

*Dangerous target*

## 10.4 Sleeping Targets

### 10.4.1 Sleeping specific AIS target

You may “sleep” an AIS target as below when the screen becomes filled with targets. Note that targets that have been activated automatically cannot be “slept.”

1. Use the trackball to place the cursor on an activated AIS target symbol.
2. Press the [F2] key to open the AIS(1) menu.
3. Press the [2] key (Sleep Target) to sleep the target.
4. Press the [MENU] key to close the menu. The target is marked with the sleeping target symbol, whose triangle is smaller than that of the activated AIS target symbol.



*Sleeping target*

### 10.4.2 Sleeping all AIS targets

1. Press the [F2] key to open the AIS(1) menu.
2. Press the [8] key (Sleep All Targets) to sleep all targets.
3. Press the [MENU] key to close the menu.

### 10.4.3 Activating all sleeping AIS targets

1. Press the [F2] key to open the AIS(1) menu.
2. Press the [7] key (Activate All Targets) twice.
3. Press the [MENU] key to close the menu.

## 10.5 Displaying Target Data

### 10.5.1 Basic target data

1. Place the cursor on an AIS target symbol.
2. Press the [ENTER/SELECT] key to show the target's basic data. The target is marked as below.

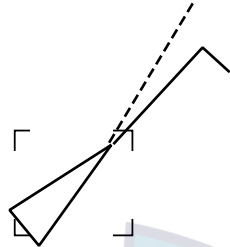

Activated target selected for data display

AIS target, fusion target no.	→ AIS 02	TRUE VECT ←	AIS target vector orientation (TRUE or REL)
Call sign	→ 1436782	6min BT ←	Vector length; BT: Bottom Tracking or WT: Water Tracking
Bearing from own ship to target	→ BRG	234.1° T	
Range from own ship to target	→ RNG	9.92NM	
Course over ground	→ COG*	321.2° T BT	
Speed over ground	→ SOG#	21.1KT BT	
CPA	→ CPA	2.8NM	
TCPA	→ TCPA	23:50	

\* = CSE (course) when water tracking mode is selected at radar.

# = STW (speed thru water) when water tracking mode is selected at radar.

Basic data display

**Note 1:** You may also show basic data by pressing the [F2] key followed by the [3] key (Basic Data). Basic data is hidden by the AIS(1) menu; close the AIS(1) menu to show basic data.

**Note 2:** If an ARPA symbol is hidden beneath and AIS symbol, press the [ENTER/SELECT] key to display ARPA data. In this case, use 3. Basic Data (or [F2] key programmed for "33. AIS DATA) on the AIS(1) menu to display AIS data.

### 10.5.2 Extended target data

1. With basic data displayed as in paragraph 10.5.1, press the [F2] key to open the AIS menu.
2. Press the [4] key (Extended Data) to display the selected target's extended data.

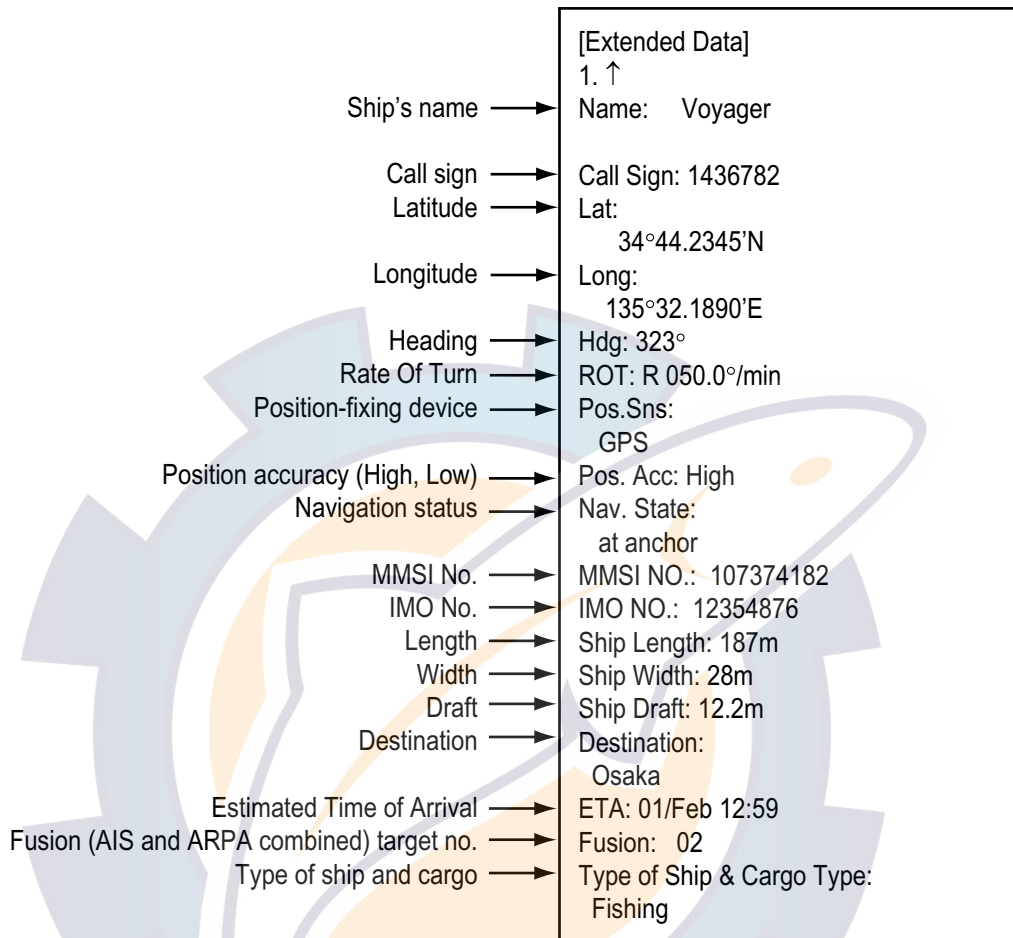

*Extended data display*

3. Press the [MENU] key to close the data display.

## 10.6 Lost Target

A target is declared a lost target when no data is received for three to five reporting intervals. When this occurs, the target is marked with the (flashing) lost target symbol and the indication "A-LOST" appears. Press the [CANCEL/CLEAR] key to acknowledge the lost target, and the lost target disappears. However, the target which becomes a lost target is a activated target or a sleeping target within the lost target range. (See paragraph 10.11.)

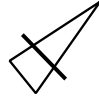

Lost target

### Confirming a lost target

1. Use the trackball to place the cursor where there is not ARPA target, marks nor lines.
2. Press the [CANCEL/CLEAR] key.

**Note 1:** You may also confirm a lost target by pressing [F2] and [5] (Lost Target).

**Note 2:** The AIS data transmission interval depends on other ship's speed. For example, the AIS data is transmitted every 10 seconds on a ship speed of 0-14 kt and every two seconds on the ship speed of more than 23 knots. For details see the owner's manual of the AIS.

## 10.7 Messages

You may display messages received by the AIS transponder as below.

### 10.7.1 Displaying messages manually

1. Press the [F2] key to display the AIS(1) menu.
2. Press the [6] key ([MESSAGE]) twice to display the MESSAGE menu.

	[Message]	
	1 [AIS(1)]	
Safety message addressed to your ship →	2 Safety Related Message (Addressed)	1
Safety message addressed to all ships →	3 Safety Related Message (Broadcast)	1
Binary message addressed to your ship →	4 Binary Message* (Addressed)	1
Binary message addressed to all ships →	5 Binary Message* (Broadcast)	1
Automatic displaying of message →	6 Auto Display On <input type="checkbox"/>	

\* = Binary messages are messages other than safety messages.

No of messages saved (Max. 5 for each type of message. 1 is the latest message.)

Message menu

3. Press appropriate numeric key among 2-5 to choose the type of message you want to see. The example below shows a safety related message (addressed).

	[Message]	
	1 [AIS(1)]	
	2 Safety Related Message (Addressed)	<input type="checkbox"/>
	3 Safety Related Message (Broadcast)	<input type="checkbox"/>
	4 Binary Message* (Addressed)	<input type="checkbox"/>
	5 Binary Message* (Broadcast)	<input type="checkbox"/>
	6 Auto Display	
	On <input type="checkbox"/>	
	=====	
Message type	→ Safety Related Message (Addressed)	
Ship sending message	→ Source ID: 012343215	
Ship receiving message	→ Dest. ID: 045673289	
Date message received	→ Date: 01/30/2004	
Time message received	→ Time: 10:32:41	
Text of message	→ Message STORM WARNING VICINITY OF 35°N 135°W.	

*Safety related message*

4. Key in the same number entered at step 3.
5. Press the [ENTER/SELECT] key to display the message.
6. Press the [MENU] key to close the message display.

### 10.7.2 Automatically displaying messages

You can automatically display a message when it is received.

1. Press the [F2] key to display the AIS(1) menu.
2. Press the [6] key ([Message]) twice to show the MESSAGE menu.
3. Press the [6] key (Auto Display) once or twice to choose ON.
4. Press the [ENTER/SELECT] key.
5. Press the [MENU] key to close the menu.

When a message is received the “message” display is automatically opened, showing the received message. To close the display, press the [MENU] key.



## 10.8 History Display

The history display shows equally time-spaced dots marking past positions of activated targets being tracked. A new dot is added at preset time intervals until the preset number is reached. If a target changes its speed, the spacing will be uneven. If it changes course, its plotted course will not be a straight line.

Below are sample history displays.

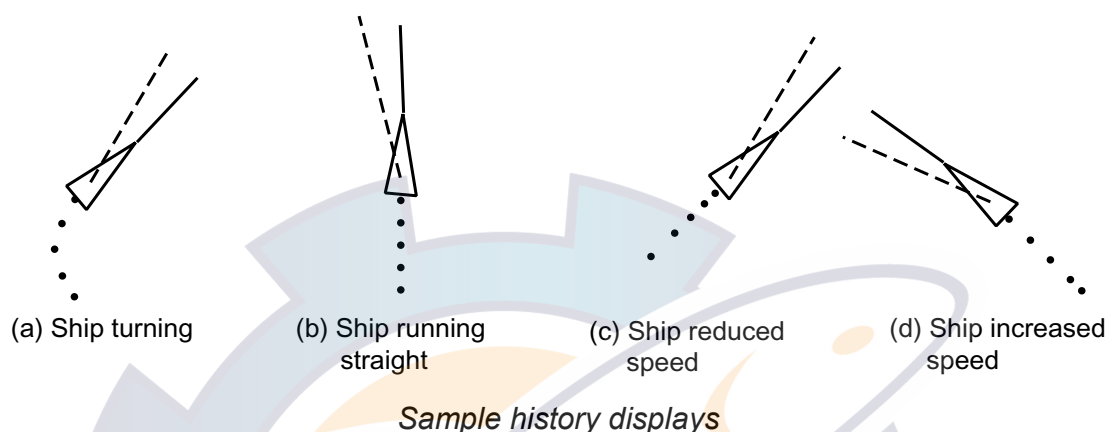

### 10.8.1 Turning history display on/off

1. Press the [F2] key to open the AIS(1) menu.
2. Press the [0] key twice to show the AIS(2) menu.

```

[AIS(2)]
1. [AIS(1)]
2. History
   On  Off 
3. History Points
    10
4. History Interval
    30sec 1
   2 3 6min
5. Symbol Color
   R* Y* G* 
   M B W*
6. ROT Tag
   000.1° /min
7. Auto Activate
   On  Off 
   Range = 000.0nm
8. Lost Target Range
   000.0nm
9.
0. [(AIS(3))]
  
```

\*: Not available on IMO-type radar.

#### *AIS2 menu*

3. Press the [2] key (History).
4. Further press the [2] key again to turn the history display on or off as appropriate.
5. Press the [ENTER/SELECT] key.
6. Press the [MENU] key to close the menu.



### 10.8.2 Choosing history display attributes

You may choose history point color, the number of history points to show per history plot interval and the history plot interval as below. Note that the color of the history points is the same as the symbol color.

1. Press the [F2] key to open the AIS(1) menu.
2. Press the [0] key twice to show the AIS(2) menu.
3. Press the [3] key (History Points).
4. Further press the [3] key to choose number of history points to display per plotting interval: 5 or 10.
5. Press the [ENTER/SELECT] key.
6. Press the [4] key (History Interval).
7. Press the [4] key again to choose history interval desired among 10, 30 s; 1, 2, 3 and 6 min.
8. Press the [ENTER/SELECT] key.
9. Press the [MENU] key to close the menu.

### 10.9 AIS Symbol Color

You may choose the color for the AIS symbols among red\*, yellow\*, green\*, cyan, magenta, blue and white\*. (\* = Not available on IMO-type radar.)

1. Press the [F2] key to open the AIS(1) menu.
2. Press the [0] key twice to show the AIS(2) menu.
3. Press the [5] key (Symbol Color).
4. Further press the [5] key to choose color desired.
5. Press the [ENTER/SELECT] key.
6. Press the [MENU] key to close the menu.

## 10.10 Automatic Target Activation

You may automatically activate all targets within a specific distance from own ship as below. Note that you may also automatically activate all targets within the ARPA's automatic acquisition zone or guard zone. When a target enters the ARPA's automatic acquisition zone or guard zone, it is automatically marked with the activated target symbol. If the activated target goes out of the ARPA automatic acquisition zone or the guard zone it still is an activated target. When a target enters the guard zone, the display shows "A-GZ" at the lower right hand corner of the display.

1. Press the [F2] key to open the AIS(1) menu.
2. Press the [0] key twice to show the AIS(2) menu.
3. Press the [7] key (Auto Activate).
4. Press the [7] key again to choose ON and then press the [ENTER/SELECT] key.
5. Press the [ENTER/SELECT] key.
6. Use the numeric keys to enter automatic activation range (000.1 to 999.9 nm).
7. Press the [ENTER/SELECT] key.
8. Press the [MENU] key to close the AIS menu.

## 10.11 Lost Target Range

Set the distance at which an AIS target is declared a lost target when no AIS data is received for six minutes or five reporting intervals, whichever is the shorter. When this feature is activated the following occurs:

- Sleeping targets within the lost target range for which no data is received are marked with the lost target symbol.
- Sleeping targets out of the lost target range are erased.
- Any activated AIS target from which you are not receiving AIS data is marked with the lost target symbol regardless of range to the target.

1. Press the [F2] key to open the AIS(1) menu.
2. Press the [0] key twice to show the AIS(2) menu.
3. Press the [8] key (Lost Target Range).
4. Use the numeric keys to enter lost target range (000.1 to 999.9 nm).
5. Press the [ENTER/SELECT] key.
6. Press the [MENU] key to close the AIS menu.

To disable this feature, enter all zeroes at step 4 in the above procedure.

## 10.12 ROT Display Setting

You may set the lower limit of the ROT (Rate Of Turn) at which the heading line on target symbols will point in direction of turning.

1. Press the [F2] key to open the AIS(1) menu.
2. Press the [0] key twice to show the AIS(2) menu.
3. Press the [6] key (ROT Tag).
4. Use the numeric keys to enter ROT (000.1 to 720.0°/min).
5. Press the [ENTER/SELECT] key.
6. Press the [MENU] key to close the AIS menu.

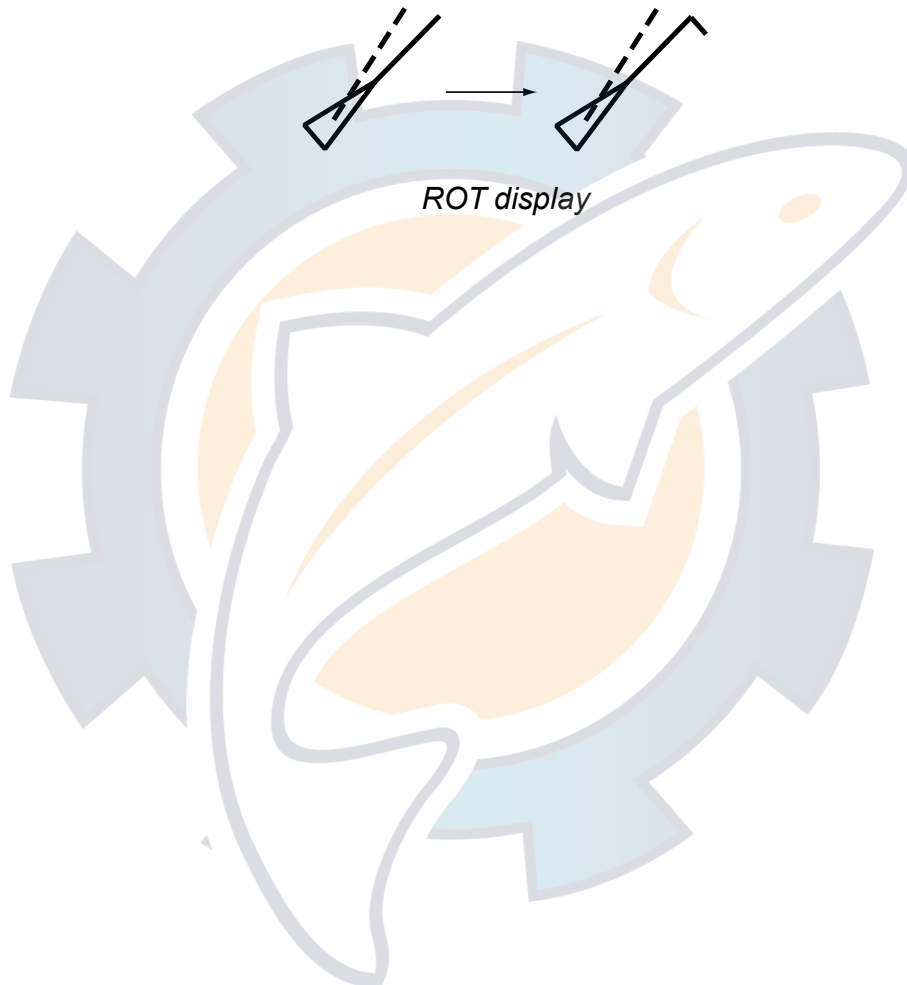

## 10.13 Combining AIS with ARPA (fusion)

If equipped with ARPA it may be jointly used with the AIS. In this case specify the parameters for which an ARPA target is converted to an AIS target.

1. Confirm that "MAN" or "AUTO+MAN" is shown at the right-hand corner of the display.
2. Press the [F2] key to open the AIS(1) menu.
3. Press the [0] key twice to open the AIS(2) menu.
4. Press the [0] key twice to open the AIS(3) menu.

[(AIS(3))

1. ↑

2. Fusion

On  Off

Posn 0.000NM

Rng 0.000NM

Brg 00.0°

Spd 0.0KT

Cse 00.0°

AIS Alarm Message

NO ALARM

*AIS3 menu*

4. Press the [2] key (FUSION).
5. Press the [2] key again to choose ON and press the [ENTER] key.
6. Enter the information below, pressing the [ENTER] key after entering each data. This information will be used to determine which ARPA targets to convert.
  - Posn: Range between AIS target and ARPA target.
  - Rng: Enter the range difference from own ship to AIS target and ARPA target.
  - Brg: Enter the bearing difference from own ship to AIS target and ARPA target.
  - Spd: Enter the speed difference between AIS target and ARPA target.
  - Cse: Enter the course difference between AIS target and ARPA target.
7. Press the [MENU] key to close the AIS menu.

If the information above is within the corresponding value of the ARPA and AIS targets, the targets are judged to be the same, the ARPA symbol is erased and only the AIS symbol is displayed. Further, "A-FSN" appears at the bottom right corner of the display at the time of conversion and the ARPA target no. appears next to the AIS symbol.

**Note:** An ARPA target whose speed is less than 1 kt is converted to an AIS target if it meets all other criteria other than course.

## 10.14 AIS System Messages

AIS system messages are displayed at the bottom right corner of the screen. The table below shows the AIS system messages and their meanings.

AIS system messages

Message	Meaning
A-FSN	ARPA target converted to AIS target. The indication disappears when the target no longer meets the criteria set for the fusion feature. When the message A-RCV is displayed, A-FSN not displayed.
A-CLSN	CPA/TCPA of an AIS target is below preset value.
A-LOST	Lost target
A-RCV	Not receiving AIS data
A-WT	This message appears when the water tracking mode is set at the radar and STW and CSE are not available. In this case the speed and course vector on the AIS symbol disappears and SOG and COG for the AIS target are displayed (on the basic display). See the table on the next page for conditions.
A-GZ	Displayed when a target enters the ARPA guard ring.
A-CPA	CPA/TCPA of the AIS target cannot be calculated because the "A-WT" alarm has been violated. *** is shown at the CPA/TCPA data location on the basic display. See the table on the next page for conditions.
A-FULL	Displayed when 1000 AIS targets have been received. (The radar can only display 1000 AIS targets closest in range to own ship.)

Ship's speed and course data and A-WT, A-CPA alarm generating conditions

Speed Source	Set/ Drift	Mode	Own ship speed data (Note 3)		Own ship course data (Note 3)		Msg when signal below is lost (IMO and Non-IMO)				Msg on IMO only	Remarks
			BT	WT	BT	WT	Log Pulse	VTG	VBW WT data	VBW BT data		
MAN	OFF	WT	VTG	MAN	VTG	GYRO			A-WT A-CPA		A-CPA	
MAN	ON	BT	VTG		VTG				A-CPA		A-CPA	See Note 2
LOG	OFF	WT	VTG	Log Pulse	VTG	GYRO		LOG	A-WT A-CPA			
LOG	ON	BT	VTG		VTG			A-CPA LOG	A-CPA		A-CPA	See Note 2
NAV	OFF/ ON	BT	VTG		VTG				A-CPA LOG			Not available on IMO spec.
LOG (S-BT)	OFF/ ON	BT	BT data of VBW		BT data of VBW and Gyro calculation						A-CPA LOG	
LOG (S-WT)	OFF	WT	VTG	WT data of VBW	VTG	BT data of VBW and gyro calculation			A-WT A-CPA	A-WT A-CPA LOG		
LOG (S-WT)	ON	BT	VTG		VTG				A-CPA	A-CPA LOG	A-CPA	See Note 2
REF	OFF/ ON	BT	Target based speed		Target based course						A-CPA	

Note 1: "VTG" means VTG or RMC data, and the order of priority is VTG>RMC. MAN means manually entered ship's speed; S/D means SET and DRIFT.

Note 2: "SET DRIFT" shown in red characters in this condition.

Note 3: Own ship speed and course data show the data which is used to calculate CPA/TCPA and WT vector of AIS targets.

## 10.15 AIS Alarm Message

The AIS(3) menu provides AIS alarm message information (\$AIALR sentence) from the AIS transponder. When an AIS alarm message is received “A-ALM” appears at the bottom right-hand corner of the screen.



# 11. MAINTENANCE, TROUBLESHOOTING

## 11.1 Replacement of Batteries

The battery icon () appears on the display when the voltage of the memory card battery or the battery on the RP Board is low. To find out which battery it is, conduct the diagnostic test as described in Paragraph 11.2. "NG" appears as a battery check results when battery voltage is low. Replace the battery at your earliest convenience.

The life of the both batteries is about three years. For replacement of the battery on the RP Board, contact your dealer.

	Battery Type	Code No.
Memory Card Battery	CR2025	000-141-093
Battery on RP Board	CR2450-F2ST2L	000-144-941

### Replacement of memory card battery

Follow the instructions below to replace the battery in a memory card. Replace the battery within 10 minutes of removal to prevent loss of data.

1. With the memory card oriented as shown below, slide the stopper on the memory card leftward.
2. Pull out the battery case and remove the battery.
3. Insert new battery in battery case positive (+) side up.
4. Set battery case to memory card.

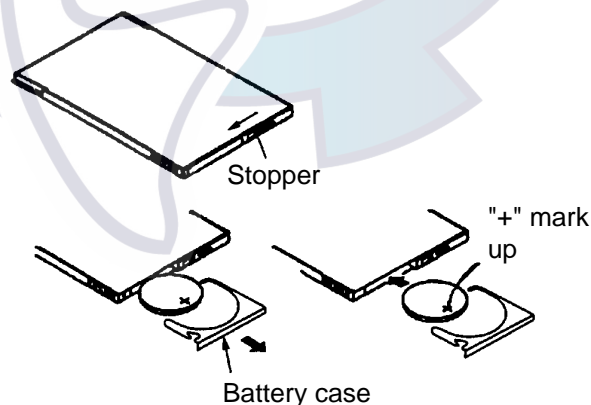

*Replacement of memory card battery*

**Note:** Dispose of used batteries according to local regulations.



## 11.2 Diagnostic Test

1. Press the [MENU] key.
2. Press the [1] key twice to show the Video Plot/AIS menu.
3. Press the [0] key twice to choose AIS/Miscellaneous1.
4. Press the [6] key twice to choose Test.

The diagnostic test displays program version no., checks the ROM, RAM, DPRAM, SRAM, internal battery, memory card battery and serial input(\*2) for proper operation, displaying OK or NG (No Good) as the check result. For NG at ROM, RAM, DPRAM or SRAM contact your agent or dealer for advice. DIP switch setting is also shown.

TEST	[RP-1]	[RP-2]
Program No.	0359219-xx*	0359220-xx*
ROM	OK	OK
RAM	OK	OK
DPRAM	OK	OK
SRAM	OK	
DIP SW (1234)	00	00
Main Board Batt.	OK	
Card Batt. (Right) *1	OK	
Card Batt. (Left) *1	OK	
Card (Right) *1	OK	
Card (Left) *1	OK	
SIO *2	--	

\*: xx = Program Version No.

### *Diagnostic test results*

- \*1: When memory card is not inserted, nothing appears for results of Card and Card. Batt. If a write-protected memory card is inserted, NG appears as results for Card.
- \*2: For factory use.

5. Press the [MENU] key to finish.

## 12. INSTALLATION

### 12.1 Necessary Parts

*Contents of RP-180 installation kit*

Name	Type	Qty	Code No.
Floppy Disk	NO.03591521XX	1	008-493-950
RP Board	14P0390A	1	
Cable Assy.	03S9456	1	000-142-369
Label (M-card)	03-134-9106	1	100-235-230
Pan Head Screw	M3x8 C2700W	5	000-881-404
Toroidal Core	TFC-25-15-12A	1	000-145-474
Cable Tie	CV-150N	1	000-570-325
Clamp	CK-05H	1	000-570-247
Shrink Tubing	3x0.25 0.1m	1	000-105-874
NH Connector Assy.		1	
Operator's Manual	OME30490-X	1	

**Note:** A PC connection cable is required to update the radar program. A cable (Type: JEC9S-XH4P-L1500, Code No. 000-145-362) is optionally available.

## 12.2 Installation

1. Turn off the display unit power switch.
2. Turn off all equipment connected to the radar.
3. Open the card slot cover at the left front of the display unit.
4. Attach label as shown below.

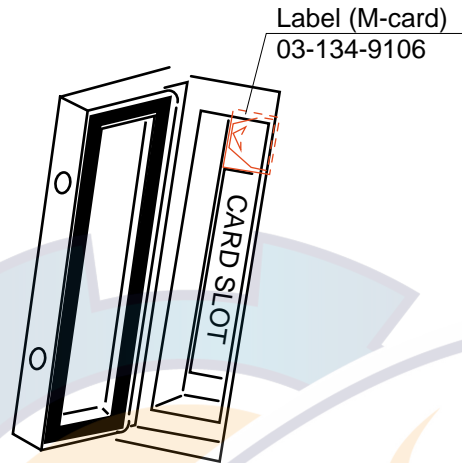

*Attachment of labels*

5. Unfasten eight screws to remove the cover.
6. Fasten the RP Board with five panhead screws.

7. Connect the cable assy. between J106 on the SPU Board and J3 on the RP Board. Attach toroidal core to cable assy. and fasten cable assy. with cable tie.

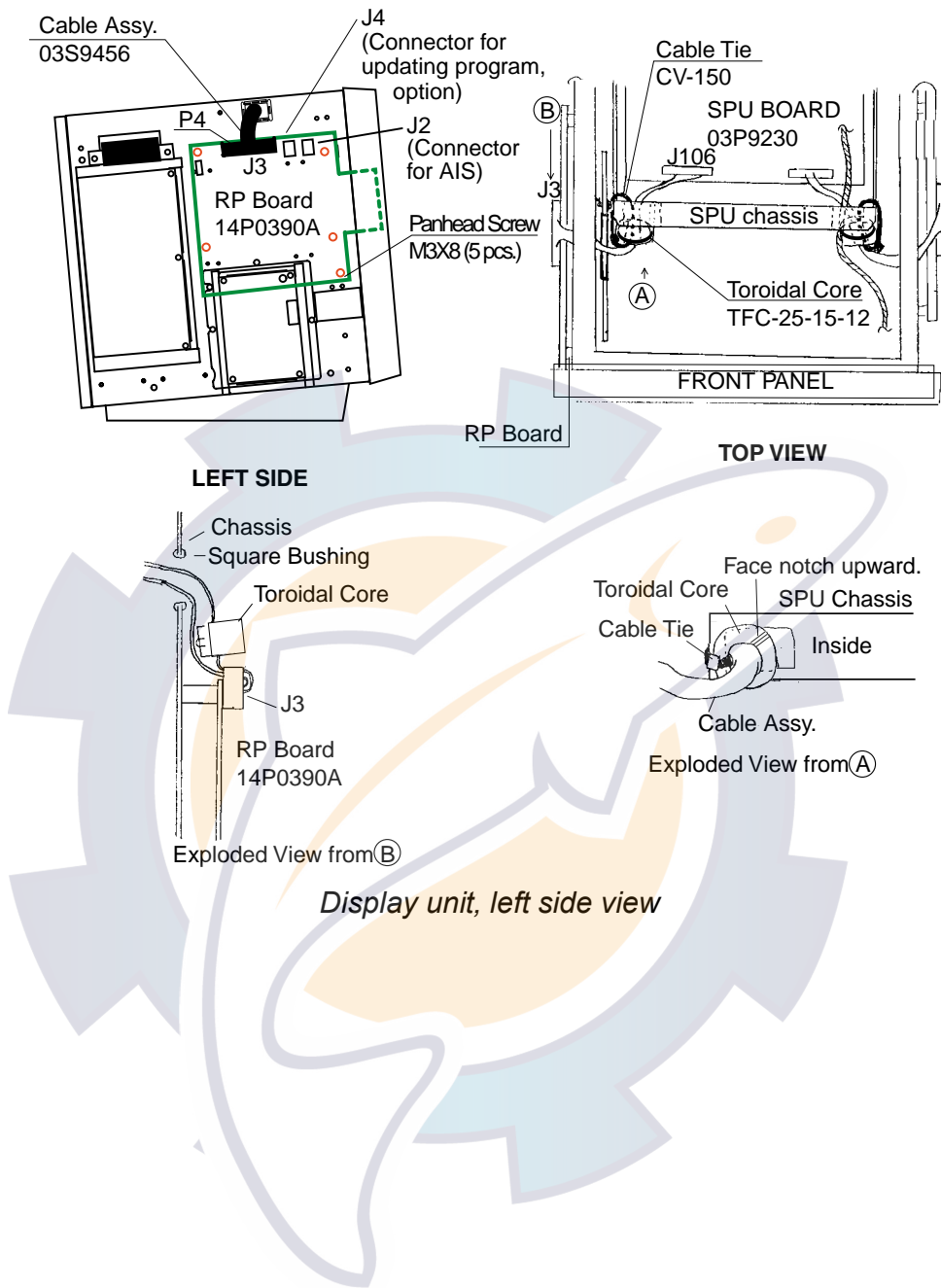

8. To connect the AIS transponder, connect the NH connector assy. (5P) to J2, routing the cable as shown below.

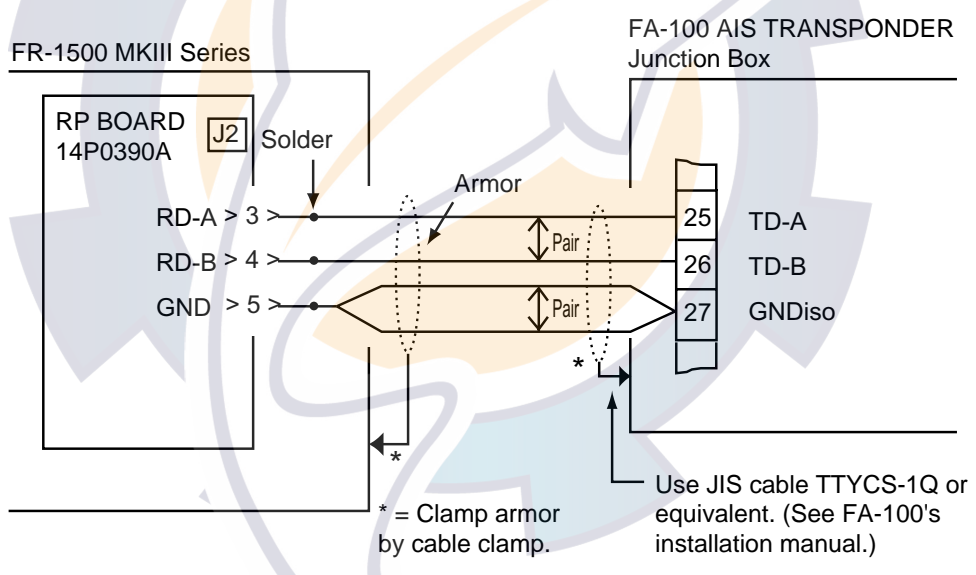
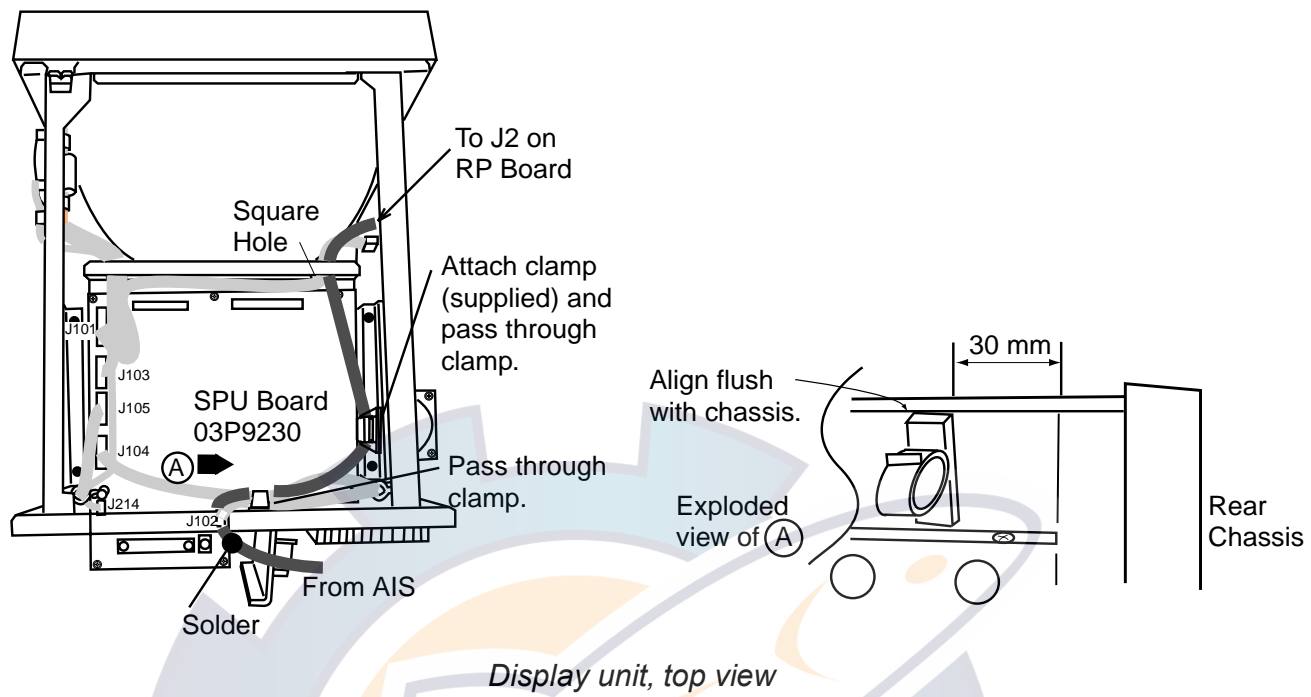

**HOW TO ATTACH NH CONNECTOR**

Shrink tubing

20 mm

Solder

(1) Cut shrink tubing in 20 mm lengths and slip onto each wire.

(2) Solder connector to signal cable.

(3) Heat shrink tubing with soldering iron.

*Connection of AIS*

9. Reattach the display unit cover.

10. Turn on the radar and conduct the self test by pressing [MENU], [0], [0], [0], [0], [2], [2].  
 Check the radar program number, at the top of the screen. If it is younger than the program number recorded on the floppy disk (supplied), the program must be updated. If updating is not required, no further adjustment is necessary; turn off the radar.

**FR-1500 M-3 SERIES TEST**

1. Program No.	03591521XX*
2. ROM Check	OK EPA OK
3. RAM Check	OK
4. Antenna Rotation	rpm
5. TX Trigger Frequency	3000Hz
6. Video Level	000
7. Video Signal	OK

**ARP TEST**

1. Program No.	18590411XX*	18590421XX*
2. ROM Check	OK	OK
3. RAM Check	OK	
4. Speed Log	OK 0.0KT	
5. Course	OK	
6. Trigger	OK	
7. Video Signal	OK	
8. Bearing Pulse	OK	
9. Heading Pulse	OK	
10. Minimum Hit	0003	
11. Scan Time	0804	
12. Manual Acq.	00	
13. Auto Acq.	00	
14. FE-Data 1	0000	
15. FE-Data 2	0000	

Press MENU key to escape  
 Press ENTER key to check CRT.

\*: XX = Program Version No.

Self test results

11. If necessary, update the program as follows:

- a) Connect the PC connection cable between the serial port (D-SUB 9 pin) on the PC and J304 on the MAIN PANEL Board of the radar. Remove rubber cap under front panel and connect XH4P connector.

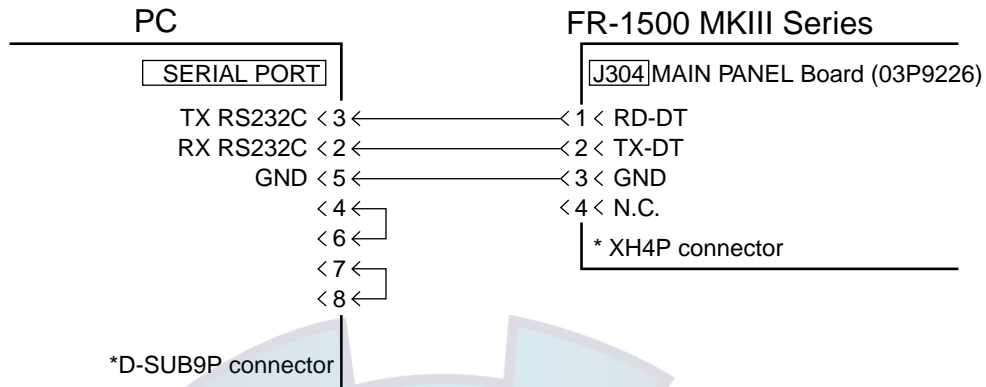

*Connection of PC to display unit*

- b) Insert supplied floppy disk in the floppy drive of the PC. Execute file (FR1500M3.bat) for version update. "TARGET POWER ON" appears on the screen of the PC.
- c) Turn on the radar. Updating begins. "Finished Version up." appears on the screen of the PC when the updating has been completed. It takes 5-6 minutes to complete the updating.
- d) Disconnect the PC from the radar.
- e) Press and hold down the GAIN control while pressing the [MENU] key five times.
- f) Press the [4] key, and then press the [ENTER/SELECT] key three times. This clears the previous program.
- g) Turn the power off and on.
- h) Press [MENU], [0], [0], [0], [2], [2]. Confirm the program version of the radar. (See the figure on page 12-5.)
- i) Press the [MENU] key to close the menu.
- j) Turn off the radar.

# APPENDIX

## 1. Digital Interface

### Input sentences (RP board, J2)

VDM, ALR, VDO

### Data reception

Data is received in serial asynchronous form in accordance with the standard referenced in IEC 61162-2.

The following parameters are used:

Baud rate: 38400, Data bits: 8 (D7 = 0), Parity: none, Stop bits: 1

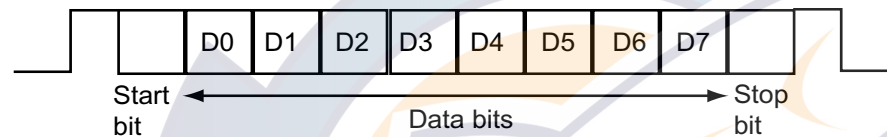

### Data sentences

#### ALR –Set alarm state

\$AIALR,hhmmss.ss,xxx,A,A,c--c\*hh<CR><LF>

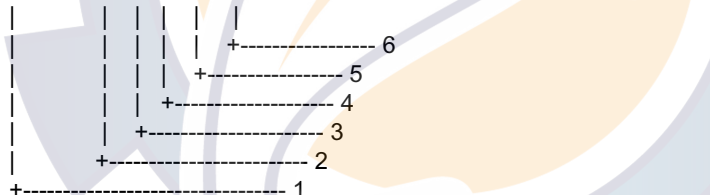

1. Time of alarm condition change, UTC
2. Local alarm number(identifier)
3. Alarm condition(A=threshold exceeded, V=not exceeded)
4. Alarm's acknowledge state, A=acknowledged V=unacknowledged
5. Alarm's description text
6. Checksum



### VDM – VHF data-link message

!AIVDM,x,x,x,a,s--s,x\*hh<CR><LF>

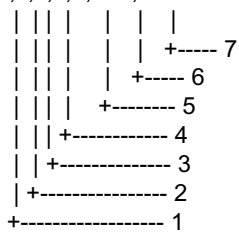

1. Total number of sentences needed to transfer the message, 1 to 9
2. Message sentence number, 1 to 9
3. Sequential message identifier, 0 to 9
4. AIS channel Number
5. Encapsulated ITU-R M.1371 radio message
6. Number of fill-bits, 0 to 5
7. Checksum

### VDO - UAIS VHF Data-link Own-vessel report

!AIVDO,x,x,x,x,s--s,x\*hh<CR><LF>



1. Total number of sentences needed to transfer the message, 1 to 9
2. Message sentence number, 1 to 9
3. Sequential message identifier, 0 to 9
4. AIS channel Number
5. Encapsulated ITU-R M.1371 radio message
6. Number of fill-bits, 0 to 5
7. Checksum

Schematic diagram

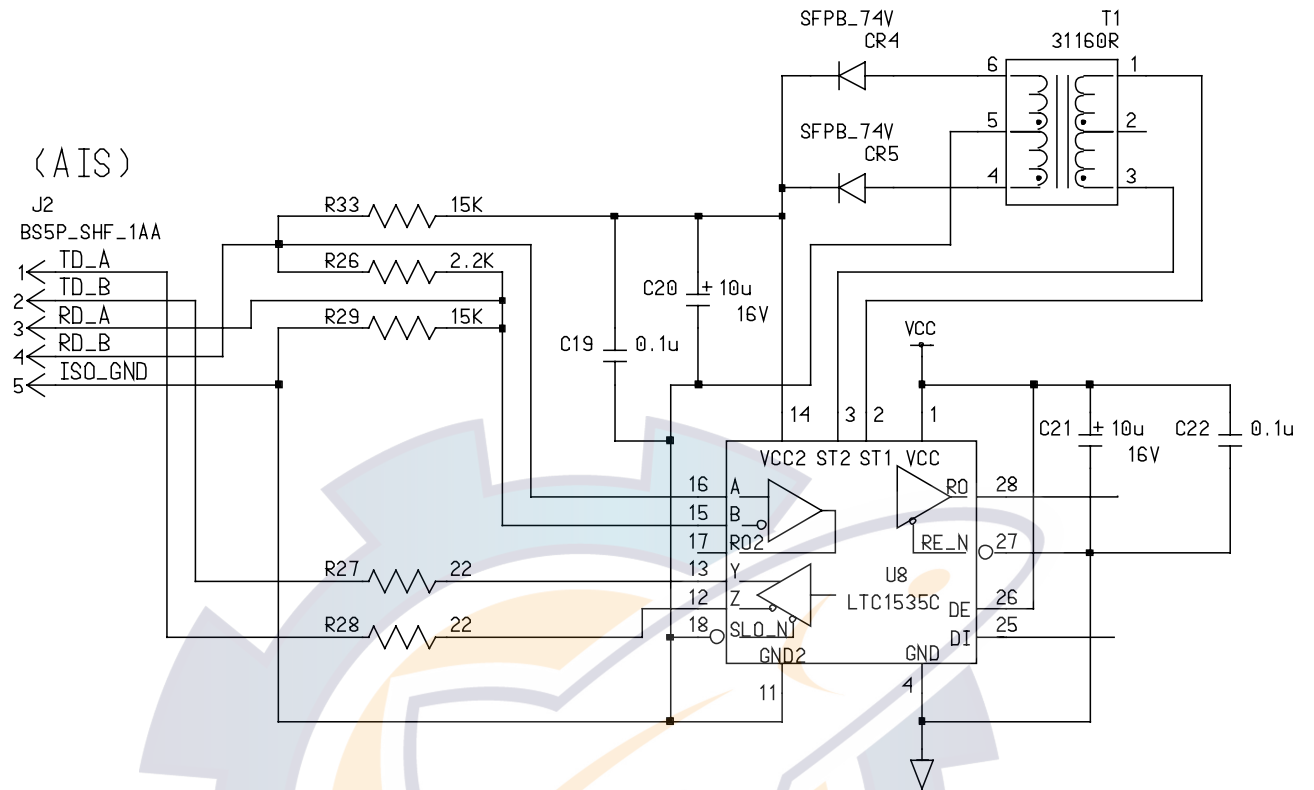

Load requirements as listener

2.2 Kohms

## 2. Interface Function

- (1) Data displayed in the Basic data display
  - !AIVDM message 1-3  
COG, SOG
  - !AIVDM message 5  
call sign
- (2) Data displayed in the Extended data display
  - !AIVDM message 1-3  
ship's position (latitude, longitude), position accuracy, navigational status, MMSI number, HDG, ROT
  - !AIVDM message 5  
call sign, ship's name, IMO number, type of ship and cargo type, dimensions of ship, electronic position fixing equipment, ETA, maximum present static draught, destination
- (3) Data displayed in the Message display
  - safety related message (addressed)
    - !AIVDM message 12  
source ID, destination ID, safety-related text
  - safety-related message (broadcast)
    - !AIVDM message 14  
source ID, safety-related text
  - binary message (addressed)
    - !AIVDM message 6  
source ID, destination ID, binary data (text telegram)
  - binary message (broadcast)
    - !AIVDM message 8  
source ID, binary data (text telegram)
- (4) Data displayed in the own ship position display area
  - !AIVDO message 1-3  
ship position (latitude, longitude)
- (5) Data displayed in the AIS alarm message display area
  - \$IALR (alarm's description text)

## 3. Main Board Modification (IEC 60936-1 related items)

When the RP-180 is installed in the radar display unit of the FR-1500 MK3 series radar, the following modifications are done to the main board (SPU board, 03P9253):

- The program of the main board (SPU board) is changed. The program no. after the change is 0359152111. (Previous program no. 0359152110)
- Modifications
  - Communication feature added between the RP-180 and the SPU board.
  - AIS menu display is added.

These modifications do not affect radar features or IEC 60936-1 related features.

## 4. Menu Tree

The example screens shown in this manual may not match the screens you see on your display. The screen you see depends on your system configuration and equipment settings.

### Video plotter menu

[MENU] key

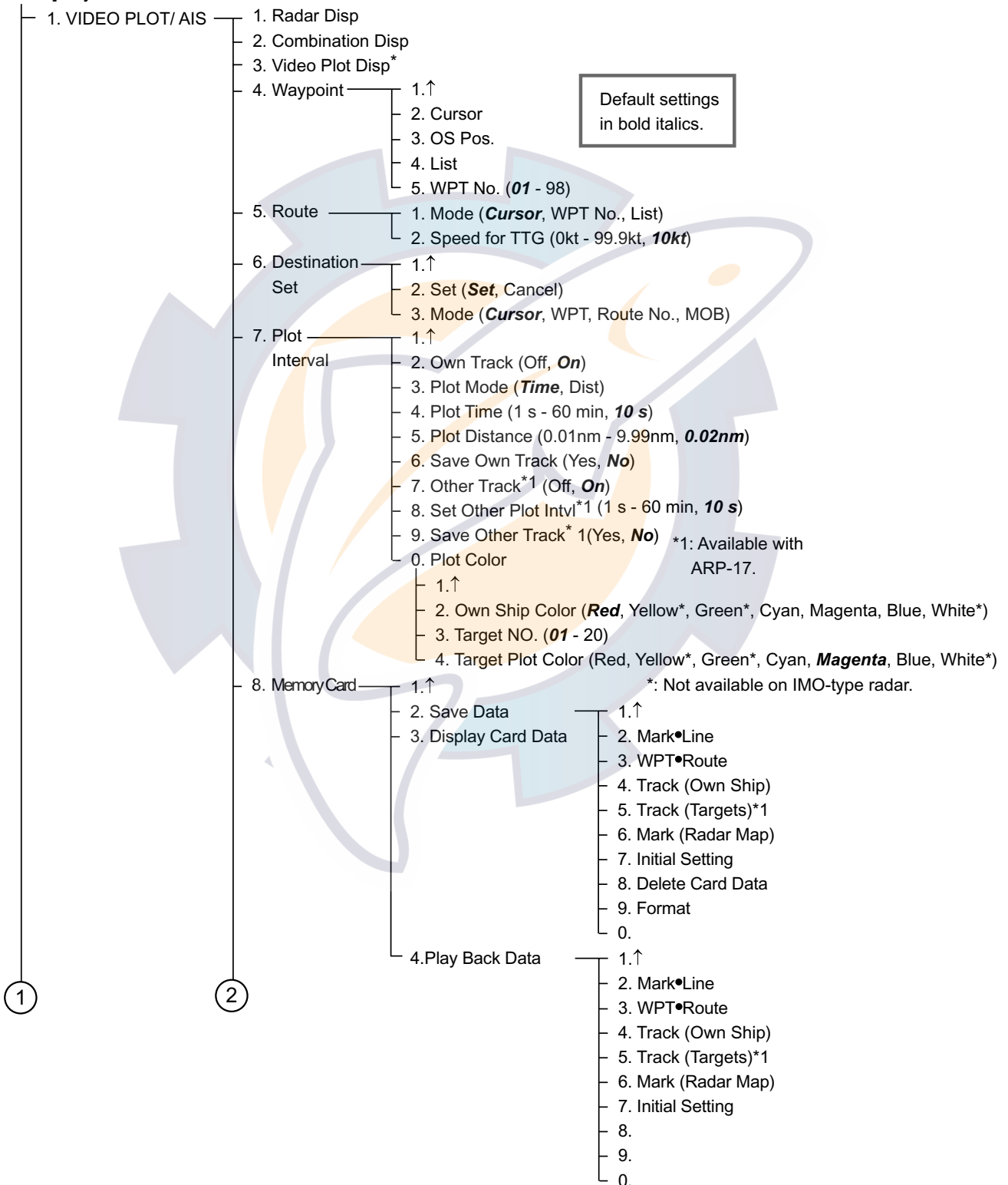

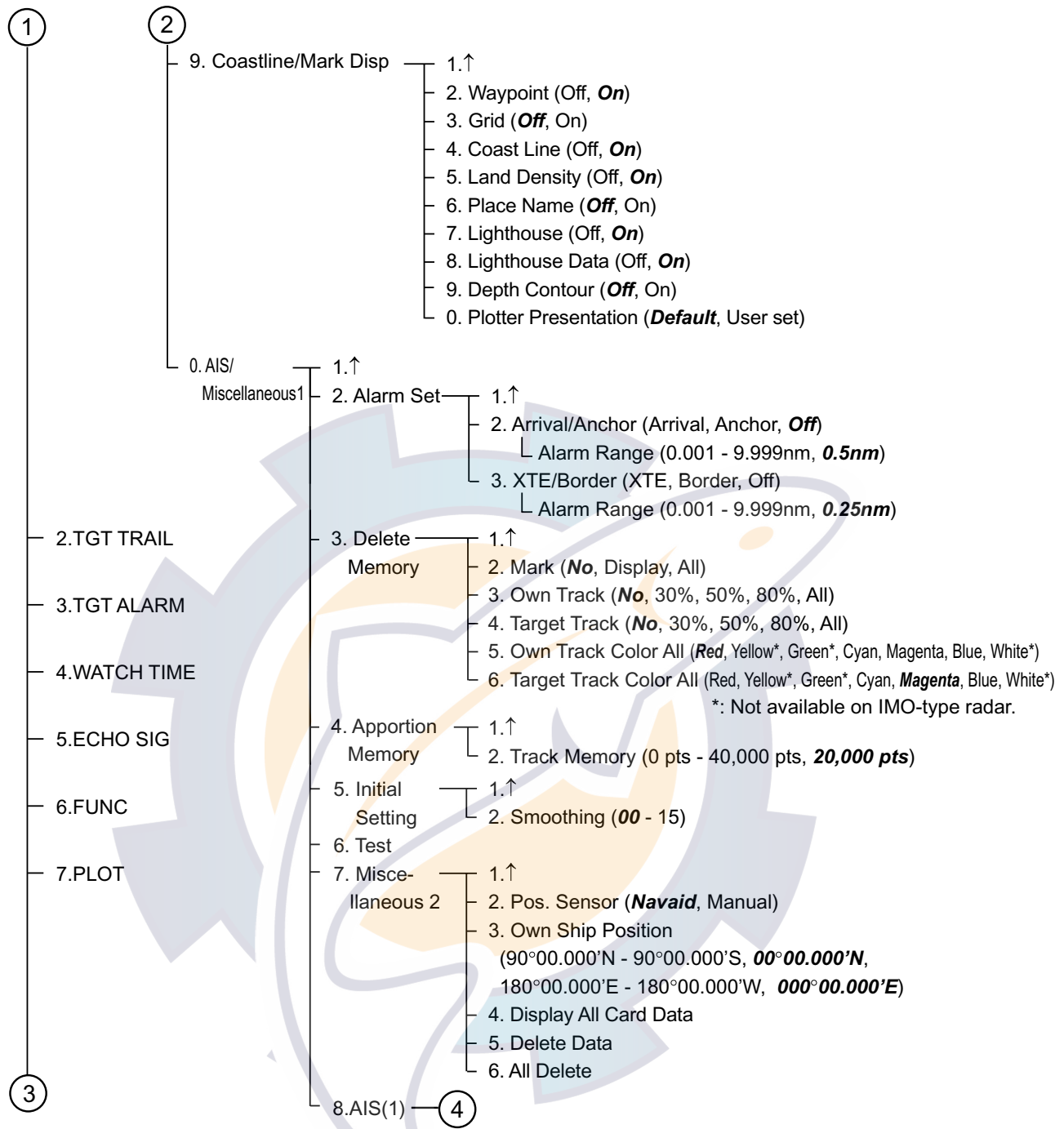

3

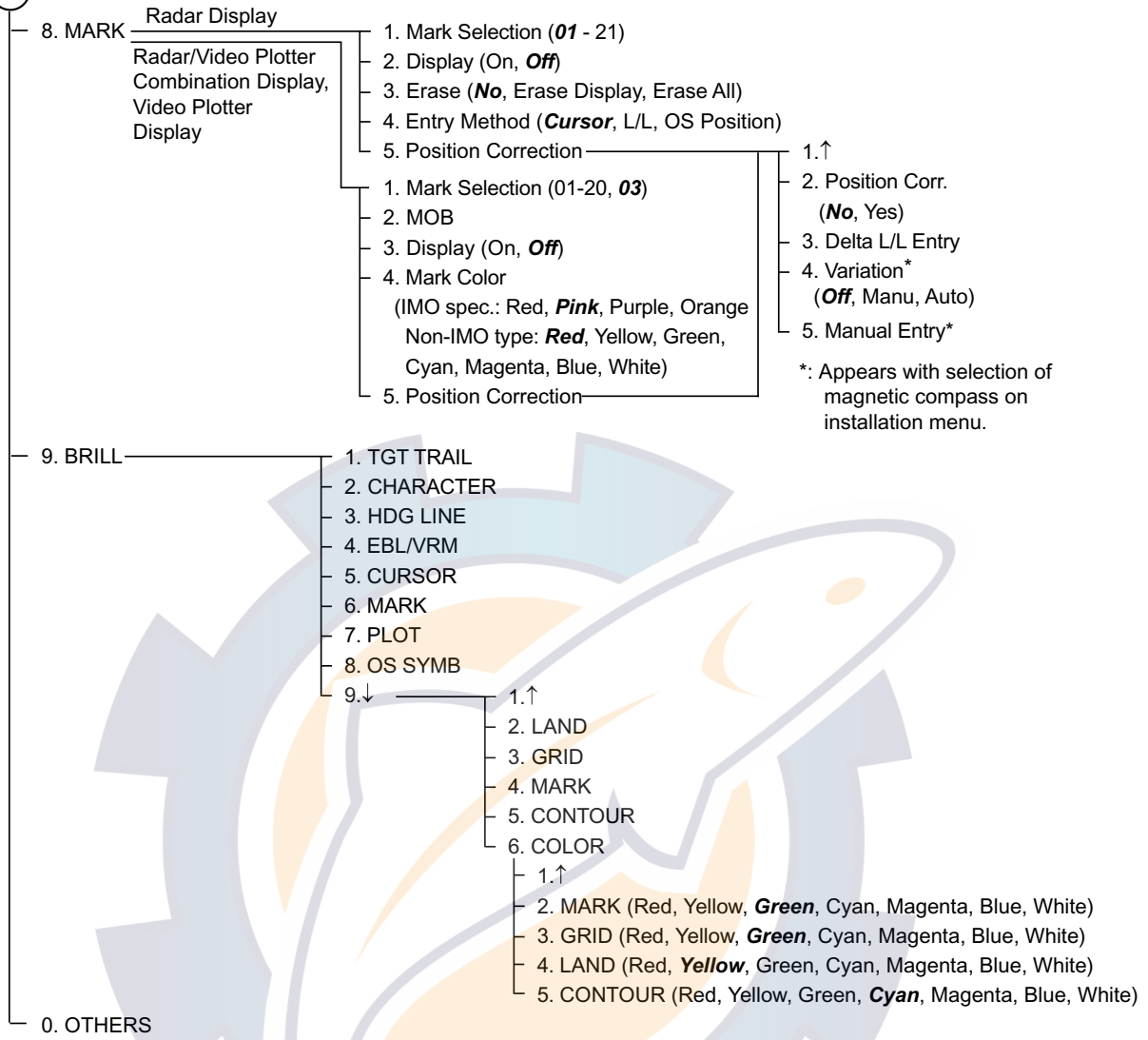



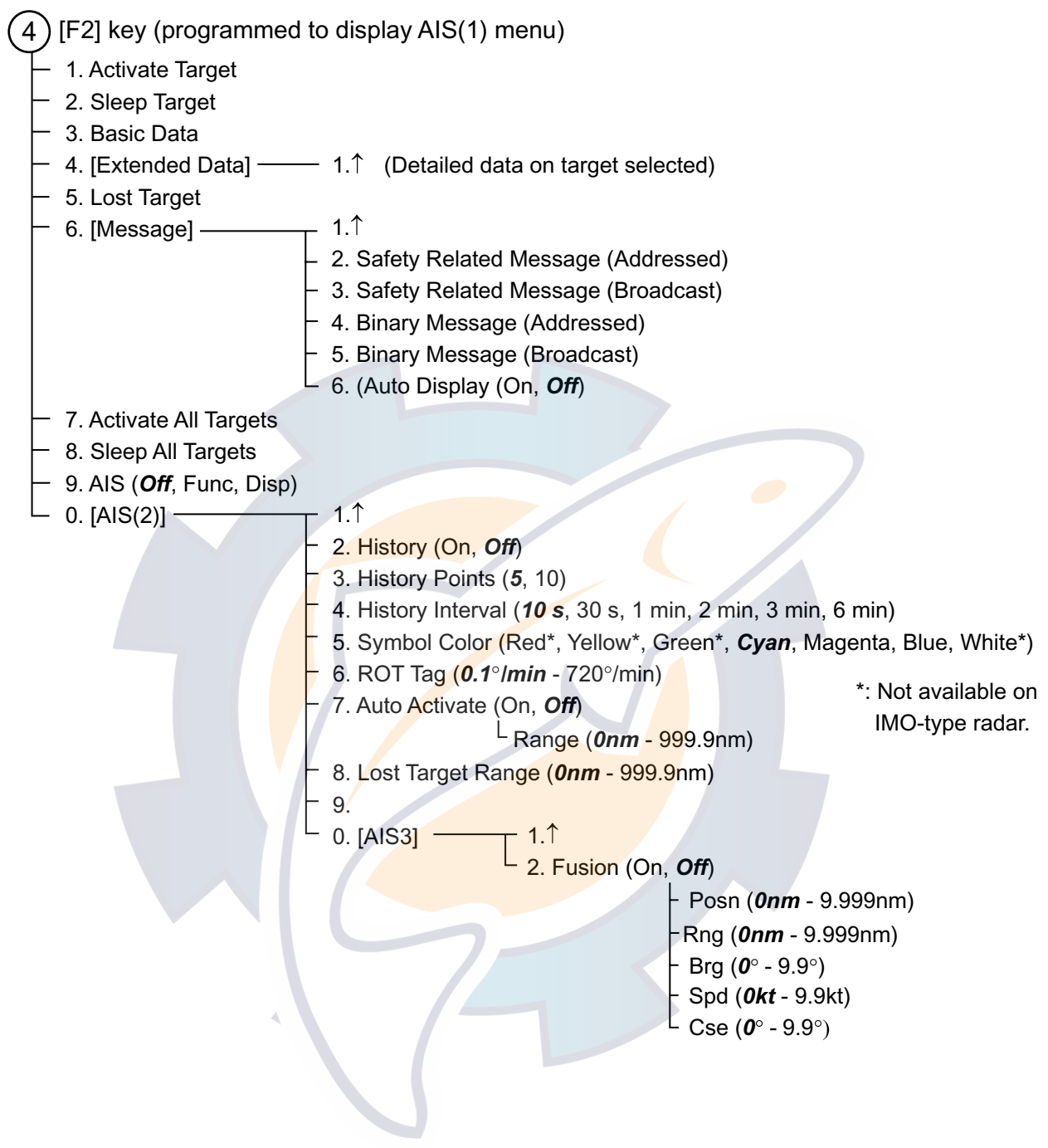

\*: Appears with selection of magnetic compass on installation menu.

**AIS menu**

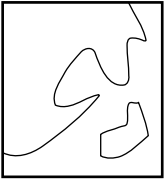

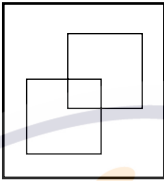
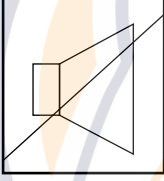
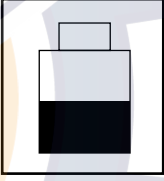
## 5. Chart Icons

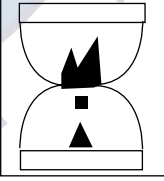
 <ul style="list-style-type: none"> <li>• Wrong chart card inserted.</li> <li>• Chart overshrunk.</li> </ul>	 <ul style="list-style-type: none"> <li>• Chart overenlarged.</li> <li>• Data reliability is low.</li> </ul>
 <ul style="list-style-type: none"> <li>• Chart properly displayed; full accuracy.</li> </ul>	 <ul style="list-style-type: none"> <li>• Chart offset applied.</li> </ul>
 <ul style="list-style-type: none"> <li>• Alarm setting violated.</li> <li>• Icon disappears when alarm is disabled.</li> </ul>	 <ul style="list-style-type: none"> <li>• Voltage of battery on circuit board or memory card is low.</li> </ul>
 <ul style="list-style-type: none"> <li>• Track recording/plotting suspended.</li> </ul>	 <ul style="list-style-type: none"> <li>• Appears while screen is being redrawn.</li> </ul>



*(This page intentionally left blank.)*



**SPECIFICATIONS OF VIDEO PLOTTER  
 RP-180**

**1 GENERAL**

- 1.1 Display Display of FR-1500 MK3 series Radar
- 1.2 Display Mode Radar picture overlaid on plotter picture
- 1.3 Presentation Mode North up (NU), True motion (TM), Course up (CU), Head up (HU),  
 Cursor Gyro (CG)
- 1.4 Display Range 0.125/0.25/0.5/0.75/1/1.5/2/3/4/6/8/12/16/24/34/48/72 (nm)
- 1.5 Projection Mercator
- 1.6 Usable-Latitude 80° or below
- 1.6.1.1.1 Coastline Data PMCIA type Furuno card and Navionics card or C-MAP, selectable
- 1.7 Track
  - Memory Capacity (pts) 3,000 for radar map 40,000 for track+mark, 20,000 for other ship track
  - Plot Interval Own ship: 1-60 s or 0.01 nm-9.99 nm, Other ship: 1-60 s
- 1.8 Mark Type Own ship, MOB, square, circle, line
- 1.9 Courseline Traced using data fed from position-fixing equipment specified
- 1.10 Alphanumeric Data Indications
  - Own ship's position (L/L)
  - Cursor intersection (L/L)
  - Range and bearing from the origin mark to the cursor intersection
  - Range and bearing to waypoint
- 1.11 Alarm Waypoint arrival/anchor watch, XTE/border

**2 AIS INDICATION**

- 2.1 Symbol Sleeping/ Activated/ Dangerous/ Selected/ Lost targets
- 2.2 Number of Targets 1,000 max.
- 2.3 Data Indication Basic and Extended data
- 2.4 Track 10 or 5 points per target
- 2.5 Alarm CPA/TCPA alarm

# INDEX

- A**
- AIS
- activating targets.....10-3
  - basic target data.....10-5
  - dangerous targets.....10-3
  - extended target data.....10-6
  - F2 key.....10-1
  - lost target.....10-7
  - messages, automatic display.....10-8
  - messages, manual display.....10-7
  - on/off.....10-2
  - sleeping targets.....10-4
  - symbols.....10-2
- Alarms
- anchor watch alarm.....7-1
  - arrival alarm.....7-1
  - border alarm.....7-3
  - Cross-track error alarm.....7-3
- Anchor watch alarm.....7-1
- Arrival alarm.....7-1
- B**
- Border alarm.....7-3
- Brilliance (chart features).....9-3
- C**
- Chart cards
- bearing correction.....2-6
  - brilliance of features.....9-3
  - displaying contents of.....2-1
  - features showing/hiding.....2-3
  - icons.....2-2
  - marker color.....9-5
  - position correction.....2-5
  - viewing contents of.....9-2
- Chart scale.....1-4
- Charts cards
- ejecting.....2-2
- Color
- markers or chart cards.....9-5
  - marks.....4-7
- Controls.....1-1
- Cross-track error.....7-3
- D**
- Data clear.....9-4
- Default settings.....9-4
- Display
- choosing.....1-2
  - offcentering.....1-3
  - shifting.....1-3
  - zoom.....1-3
- M**
- Marks
- choosing entry method.....4-3
  - color.....4-7
  - entering at cursor position (combination, video plotter displays).....4-4
  - entering at cursor position (radar display).....4-3
  - entering at own ship's position (combination, video plotter displays).....4-4
  - entering at own ship's position (radar display).....4-3
  - entering by latitude and longitude position (radar display).....4-3
  - erasing from combination, video plotter displays.....4-5
  - erasing from radar display.....4-5
  - erasing individual.....4-5
  - MOB mark.....4-6
  - on/off.....4-1
  - Origin mark.....4-7
  - selection of (combination, video plotter displays).....4-4
- Memory apportioning.....9-6
- Memory cards
- displaying contents.....8-5
  - erasing files from.....8-7
  - formatting.....8-1
  - playing back.....8-6
  - saving screen contents to.....8-3
- MOB mark.....4-6
- N**
- Navigation
- cancelling.....6-4
  - navigating a route.....6-3
  - navigating to a waypoint.....6-1
  - navigating to cursor-selected point.....6-2
  - navigating to MOB position.....6-3
  - skipping route waypoints.....6-4

**O**

Offcentering ..... 1-3  
Origin mark ..... 4-7

**P**

Presentation mode ..... 1-2

**R**

Routes

creating from route list ..... 5-6  
creating with cursor ..... 5-4  
creating with waypoints ..... 5-5  
deleting route waypoints ..... 5-8  
routes ..... 5-8  
turning display of on/off ..... 5-7

**S**

Shifting the display ..... 1-3  
Ship's position input ..... 9-1  
Smoothing ..... 9-2

**T**

Track

color ..... 3-6  
display other ship's ..... 3-4  
displaying own ship's ..... 3-1  
erasing ..... 3-5  
plotting interval (own ship) ..... 3-3  
stopping plotting of own ship's ..... 3-2

**W**

Waypoints

deleting ..... 5-3  
entering at cursor position ..... 5-2  
entering at own ship's position ..... 5-1  
entering by latitude and longitude ..... 5-2  
on/off ..... 5-1

**Z**

Zoom ..... 1-3

