

# ORVIS®

## ROD AND TACKLE

### Battenkill® Bar Stock Reel

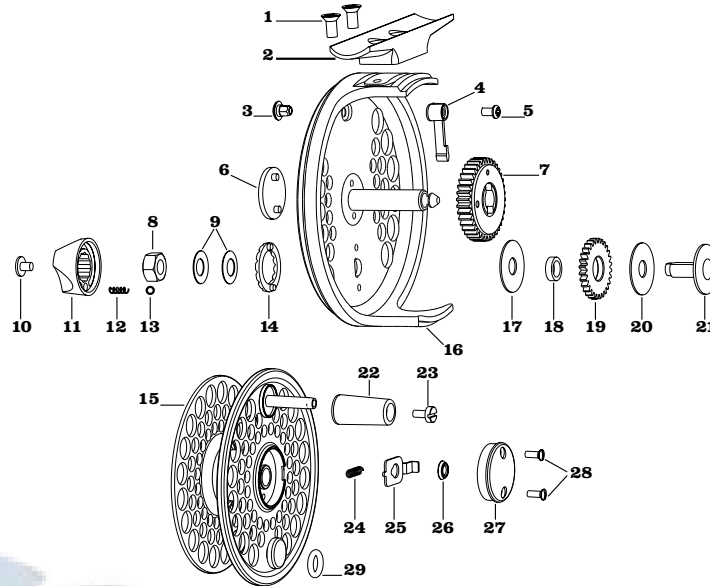

#### REEL ASSEMBLY

- |  |   |   |   |
|--|---|---|---|
| <ul style="list-style-type: none"> <li>1 Foot Screws</li> <li>2 Reel Foot</li> <li>3 Clicker Grommet</li> <li>4 Clicker</li> <li>5 Clicker Screw</li> <li>6 Logo Disc</li> <li>7 Drive Gear</li> </ul> | <ul style="list-style-type: none"> <li>8 Drag Adjustment Nut</li> <li>9 Spring Washers</li> <li>10 Drag Knob Screw</li> <li>11 Drag Knob</li> <li>12 Detent Spring</li> <li>13 Detent Ball</li> <li>14 Detent Plate</li> <li>15 Spool Assembly</li> <li>16 Body Assembly</li> </ul> | <ul style="list-style-type: none"> <li>17 Rulon® Drag Washer</li> <li>18 Drag Gear Bearing</li> <li>19 Drag Gear</li> <li>20 Rulon Drag Washer</li> <li>21 Drag Spindle</li> <li>22 Handle Knob</li> <li>23 Knob Screw</li> <li>24 Quick-Release Spring</li> <li>25 Quick-Release Slider</li> </ul> | <ul style="list-style-type: none"> <li>26 Oiler Pad</li> <li>27 Quick-Release Cover</li> <li>28 Cover Screws</li> <li>29 Leader-Loc O-Ring</li> </ul> |
|--|---|---|---|

<b>BATTENKILL BAR STOCK REEL</b>					
<b>Capacity Chart</b>					
LINE WEIGHT	I	II	III	IV	V
<b>WF1</b>	<b>100</b>				
<b>WF2</b>	<b>75</b>				
<b>WF3</b>	<b>50</b>	<b>125</b>			
<b>WF4</b>		<b>100</b>			
<b>WF5</b>		<b>75</b>	<b>125</b>		
<b>WF6</b>			<b>100</b>		
<b>WF7</b>			<b>75</b>	<b>150*</b>	
<b>WF8</b>				<b>125*</b>	
<b>WF9</b>				<b>100*</b>	<b>200*</b>
<b>WF10</b>					<b>175*</b>
<b>WF11</b>					<b>150*</b>

#### Battenkill Bar Stock Reel Specifications

- I Reel** | weight: 3.2 oz. | 2½ inches    **IV Reel** | weight: 4.5 oz. | 3⅜ inches  
**II Reel** | weight: 3.5 oz. | 2¾ inches    **V Reel** | weight: 5 oz. | 3⅝ inches  
**III Reel** | weight: 3.9 oz. | 3 inches

#### Capacity in Yards

All capacities are quoted using 20-lb Dacron® backing unless otherwise noted.

\*30-lb Dacron.

# ORVIS®

## ROD AND TACKLE

### Battenkill® Bar Stock Reel

#### INTRODUCTION

The Battenkill BBS fly reels features include:

- Fully machined from bar-stock aerospace-grade aluminum with an anodized finish for durability.
- Extremely lightweight design.
- Easily interchangeable spool.
- Left- to right-hand changeover in seconds with absolutely no tools required.
- Smooth and dependable Battenkill drag system.
- Generous backing capabilities.

#### DRAG OPERATION

Battenkill BBS reels feature the familiar Battenkill multi-stage disc drag system to ensure smooth stopping force.

To adjust the drag, turn the knob clockwise to increase resistance, and counter-clockwise to decrease it. The minimum drag setting should never be less than the pressure required to prevent over-running of the line on fast runs. Additional drag may be applied by palming the spool rim with your fingers or palm.

The easy drag adjustment is infinitely variable, providing wide-ranging and controllable settings. The drag assembly has been factory-adjusted, but may require some fine tuning after continued use and wear of the drag components. If drag pressure is insufficient, the range may be adjusted by using the following procedure:

1. Turn the drag adjustment knob fully counter-clockwise.
2. Remove screw **A** from the outside of the drag knob **B**.
3. Remove the drag knob, taking care not to lose the ball and spring.
4. Turn the drag adjustment nut clockwise to increase drag, counterclockwise to decrease it.
5. Replace the drag knob in the same position it was in when you removed it and replace the screw.
6. Test the drag. If the pressure is still incorrect, the above procedure may be repeated until the desired range is achieved.

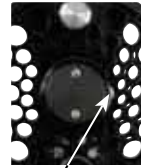

FIGURE 1

#### SPOOL REMOVAL

The spool release is located in the middle of the reel spool (figure 1). To remove, depress the spool release latch, while simultaneously lifting the spool out of the reel body.

#### LEADER-LOC

The Battenkill BBS features Orvis' Leader-Loc system, which can be used to prevent the leader from binding under your line during storage. Simply wrap the leader around the counterweight and it is firmly held until required.

All Battenkill Bar Stock reels are designed for use in saltwater conditions. See routine maintenance for saltwater care.

#### RETRIEVAL CONVERSION

All Battenkill BBS reels have the drag factory installed for left-hand wind. To change your reel to right-hand wind, simply slide the ratchet gear off the center spindle, turn it over so the "R" faces you, and slide the gear back over the center spindle. The reel is now set for right-hand wind.



#### ROUTINE MAINTENANCE

Your new Battenkill BBS reel has been properly lubricated prior to shipping. However, it should be cleaned and lubricated after extensive use or after contact with dirt, sand, or saltwater. Your reel should receive routine cleaning and maintenance at least twice each year. Lightly lubricate all moving components—handle, center spindle, and gear shaft with Penn Reel Lube, available in tackle shops. After lubrication, check screws for proper tightness. Do not put the reel away wet, or into a wet reel case or tackle box.

Following use in saltwater, the reel should be rinsed in fresh water and all parts, except drag surfaces, lightly oiled. The body and spool should be wiped with a lightly oiled cloth.

For extended storage, remove both line and backing and loosen the drag.

#### SERVICING

Your reel should be routinely serviced, cleaned, and lubricated twice each year, or more frequently if the reel is used for extended periods in salt water. The service procedure is as follows:

1. Thoroughly clean the reel as described above in the 'Routine Cleaning' section. For thorough cleaning, the front drag cover (#20) can be moved. **Before removing the drag cover, the drag must be set to minimum.** If adjustment of the drag system is required, refer to 'Drag Adjustment' section.
2. Lightly lubricate all moving parts—handle, quick release, bearings, and center spindle—with reel lube, available from tackle shops. **Do not allow lube into the drag system, as this will diminish the drag performance of the reel.**
3. Wipe the body and spool with a lightly oiled cloth.
4. Check all screws for tightness.

#### GUARANTEE

Your Orvis Battenkill BBS reel is unconditionally guaranteed against defects in materials and workmanship.

If you have any problems, simply send your reel and a \$10 check to the following address:

By USPS Mail: Orvis; Overhaul Services; 178 Conservation Way; Sunderland, VT 05250.

By FedEx or UPS: Orvis; Overhaul Services; 4182 Main St.; Manchester, VT 05254.

If the reel is in any way defective in materials or workmanship, your \$10 repair check will be returned to you at once.

Your reel will be completely serviced (cleaned, lubricated, and returned to you postpaid) for a fee of \$10, plus cost of parts.

Damaged reels can be repaired on an individual basis and repair work will be billed at the hourly shop rate, plus parts. We will provide a written estimate upon receipt of the reel prior to any work being done.

#### QUESTIONS?

If you have any questions about the operation and maintenance of your new reel, Orvis Technical Advisors are always available. Email: [info@orvis.com](mailto:info@orvis.com).

Phone: 1-800-778-4778.