

Scotty®

Manual Downrigger

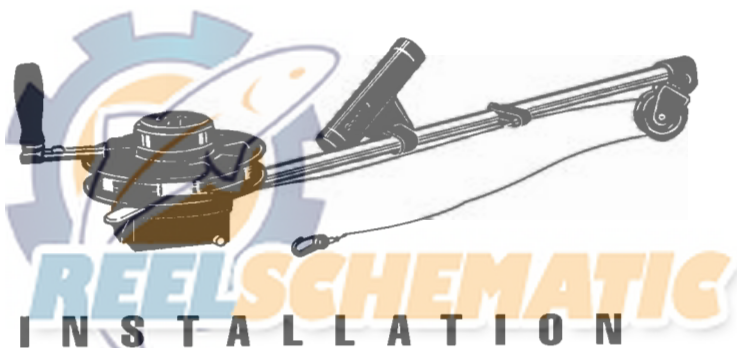

U S E A N D S A F E T Y

M A I N T E N A N C E

CAUTION! Read through this entire booklet before operating your Scotty downrigger! Improper use may damage your downrigger and void warranty. You may also expose yourself to unnecessary danger and physical injury.

I N T R O D U C T I O N

Thank you for choosing a Scotty Downrigger. In 1973 Scotty produced its first downrigger. Our goal was to manufacture a superior downrigger, built to withstand the demanding marine environment, and we now produce many manual and electric models. This instruction book will give you basic instruction on mounting and using your downrigger. Please read it carefully. It will improve your results and also give you important tips on downrigger safety and care.

Good Fishing!

F E A T U R E S

Auto Brake

Releases automatically when winding up downrigger, and sets automatically when the handle is released.

Clutch Brake

The Scotty clutch brake allows descent of the downrigger at any speed you choose. Most of the time you will want a uniform slow speed to avoid tangles. However, in instances where you want a lure deep very quickly, the Scotty will respond, giving you complete control. In addition, the clutch brake can be set so that it will slip if you hang up on the bottom. Many times you can then turn the boat around and lift the weight free without losing anything.

Limited Lifetime Warranty

Through the use of non-corrosive materials and sound engineering, Scotty is proud to warranty all its manual downriggers for the lifetime of the original owner. We will also back our customers with fast, direct factory service and do our best to get them back fishing as fast and inexpensively as possible. Please read the warranty agreement carefully and retain the certificate section in a safe place.

Horizontal Spool Design

Low Profile Horizontal spool design for easy winding and compact storage.

Positive Drive Depth Counter

Spray protected, positive drive depth counter, reads in feet.

Extendable Handle Arm

Models No. 1060, 1080, 1085, and 1090 have an extendable handle arm for extra cranking leverage and a fast retrieve two foot per turn spool.

FISHING WITH DOWNRIGGERS

Downrigger fishing is a whole new style of trolling. It will take a little while to get used to it, but after you begin to catch fish with it, you'll never go back to using heavy tackle. Unlike conventional trolling, the first evidence of a strike may show with just a wiggle of your rod tip or your downrigger pulley. Often the downrigger boom will bounce up and down as the fish pulls against the release clip. The line will then (usually) pull free from the clip, your fishing line will go slack momentarily, then zing-g-g! You have your fish on the line with no weight at all. Quite often, the fish will rush to the surface (with no weight to hold him down) and put up a spectacular fight right on top.

After a strike, note the reading on the depth counter so you can get your line back to the exact same depth after you land the fish. Many suspended fish travel in schools. By returning to the exact same location you will have an excellent chance of hooking up again.

If the fish is large we suggest you retrieve the downrigger before you land the fish. This eliminates the possibility of the fish tangling in the downrigger line or of the weight hitting bottom if you drift into shallow water while playing the fish. You should wind up all downriggers on the boat before you stop to drift. This will avoid tangles. If fishing alone, you should get your fish under control and then retrieve the downrigger.

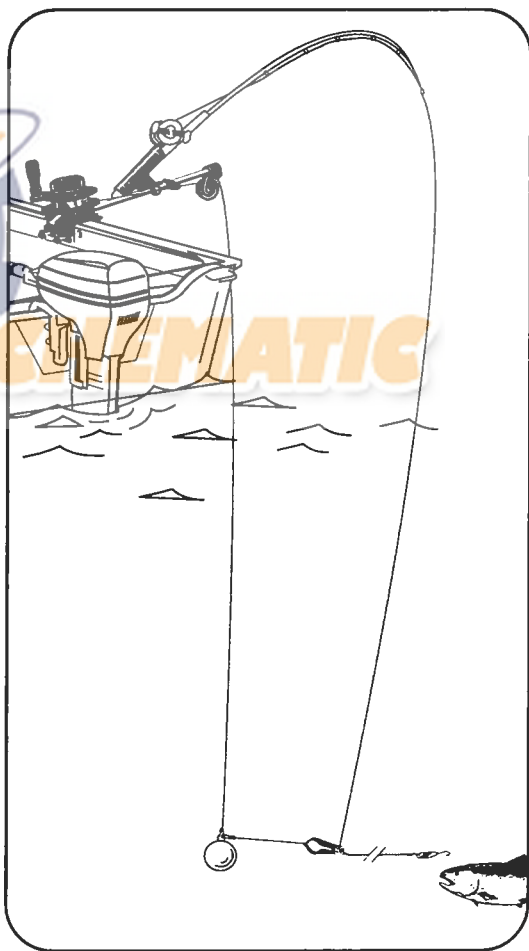

DOWNRIGGER SAFETY

The Scotty Models No. 1085 and No. 1090 are designed for use on wide beam boats of 16 ft. long and up. Installation on smaller boats is not recommended. All sports have some physical hazards connected with them and fishing with a Downrigger calls for some common sense and precaution. There are natural physical forces associated with long armed downriggers. The load or strain at the mounting point of a downrigger is proportional to the length of the arm. With a 30 inch arm and 150 lb. breaking strain trolling wire, this pulling force and the arm leverage can exert a force of approximately 1100 lbs. on the gunnel of your boat. It is obvious that this force could overcome a weak mounting point on the boat. In the case of a small boat, it could cause the boat to submerge or overturn if the wire is caught on the bottom in a strong tide or in a heavy wind.

HERE ARE SOME SAFETY TIPS THAT SHOULD BE OBSERVED WHEN YOU ARE DOWNRIGGER FISHING, PARTICULARLY IN OCEAN OR TIDAL CONDITIONS.

Care must always be exercised to avoid tangling your downrigger wire in your boat prop. The best way to avoid this risk is to mount the downrigger near the stern of the boat so that the wire never gets under the boat in a turn. Sharp turns should be avoided and you should never back up with the downrigger wire out.

If your model has the tilt-up base and the downrigger is tilted up, the boom must be tilted back past vertical, and the red lock lever tucked fully under the downrigger base. **Keep your fingers away from the underside of the downrigger base and remove the lead weight when the downrigger is tilted up or unattended.**

Make sure the area where you are mounting your Downrigger is strong and reinforced. If it is weak, reinforce it with a backing plate of wood or metal.

Don't attempt to retrieve a weighted or snagged downrigger cable by hand. Wave or boat motion could cause serious injury.

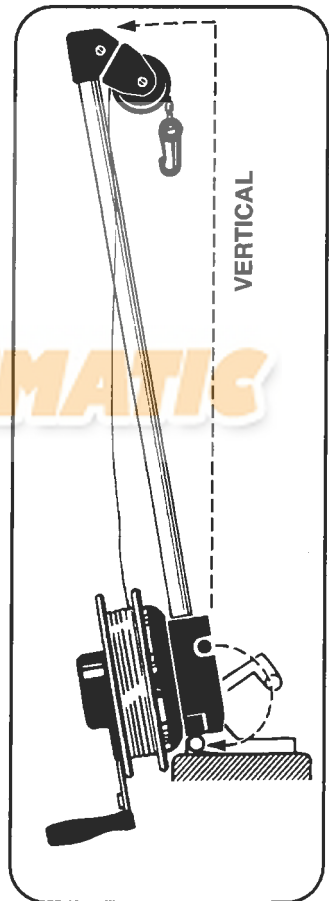

Red lock lever must be tucked under base to lock the downrigger upright

WHAT HAPPENS WHEN YOU HIT BOTTOM?

When your weight touches bottom while trolling, you will see the downrigger boom bounce in a manner similar to a fish strike. You should immediately wind up to a safer depth. **WARNING!** Be very cautious when fishing in strong tidal current or on windy days. If the weight or wire snags on the bottom, the force of the tide or wind on the boat can put terrific strain on the downrigger. **KEEP a sharp pair of wire cutters handy in case you have to cut the wire in an emergency.** Because of the built in tilt-up feature, the downrigger boom may fly up quickly when the wire breaks, or is cut, **so be sure to stand clear, not leaning over the boom.**

We always recommend you have a large scale chart of your fishing area and try to know your position at all times when deep trolling. With a relatively smooth bottom, if the lead weight hangs up on a small ledge it can often be released by turning around and pulling from the opposite direction, providing there is relatively little tide or wind and your boat is easy and responsive in handling. The wire line can be played out if necessary while you turn the boat to the direction of the hang-up. After a hang-up the wire should be examined for any broken strands. If strands are broken, it should be cut and rejoined. As a temporary alternative, the free strands should be carefully tucked and woven back into the remaining lays. The wire is now reduced in strength and if there is further and continued breaking of the strands, replace the wire.

The built-in Scotty brake handle stop will allow the brake to slip if you hang up on the bottom. This will allow you to stop your boat while it is slipping and decide your best strategy. Most times you can turn the boat around, and while pulling from the opposite direction, lift the weight free without losing anything.

MOUNTING INSTRUCTIONS

Our recommendations with regard to mounting locations are:

Downriggers work best if they are mounted near the stern of the boat. They will work at any location but the risk of tangling wire line in your prop during a turn is minimized the further back the downrigger is mounted.

The downrigger should be mounted in a location where it is easy to reach and operate. Remember you will be handling heavy weights on and off and you will be setting lines and releases. The downrigger needs to be convenient for these activities. Do not mount it where you have to reach or lean a long way to make the connections.

A rod holder should be mounted close to each downrigger, but be sure to allow clearance for the rod in the holder. Otherwise the butt of the rod may interfere with the downrigger reel. Allow enough clearance so the rod can easily be removed from the rod holder when you get a strike. Scotty makes several models of rod holders that work well with our downriggers. (Inquire at your supplier.)

FOR MODELS NO. 1050 AND 1060

These models mount on the No. 1010 slide-in mounting bracket supplied with the downrigger. This bracket should be securely mounted to the boat as shown below. Slide downrigger into the mounting bracket and secure with lock bar.

We recommend that a wood or metal backing always be installed on the underside of the mounting surface. This spreads the load and avoids damage to the boat, in the event of a bottom hang up.

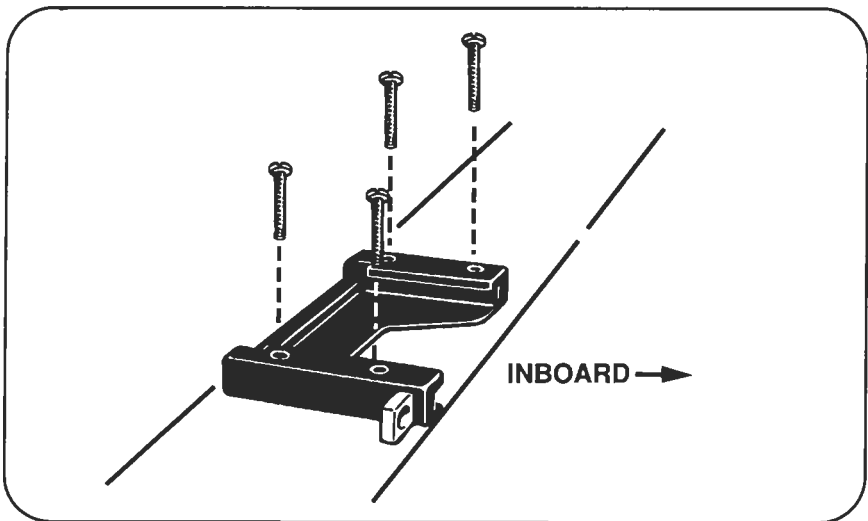

MOUNTING INSTRUCTIONS

FOR MODELS No. 1080, 1085 and 1090

These models mount on the Scotty #1023 tilt-up mounting bracket supplied with the downrigger. This bracket should be securely mounted to the boat as shown below. The downrigger can be mounted over the side of the boat, over the stern or off the corner. The mounting bracket must be mounted on a flat surface and the rear of the bracket must be within 1/4" of the edge of the gunnel so that the downrigger spool has clearance for tilting (see diagram). Because of the heavy stresses placed on the boat gunnel by the leverage of the long downrigger arm, we recommend that a wood or metal backing plate always be installed on the underside of the mounting surface. This spreads the load and avoids damage to the boat, in the event of a bottom hang up.

Position the downrigger on the tilt bracket. Insert the stainless steel mounting bolt through the mounting bracket and downrigger base. Hand tighten.

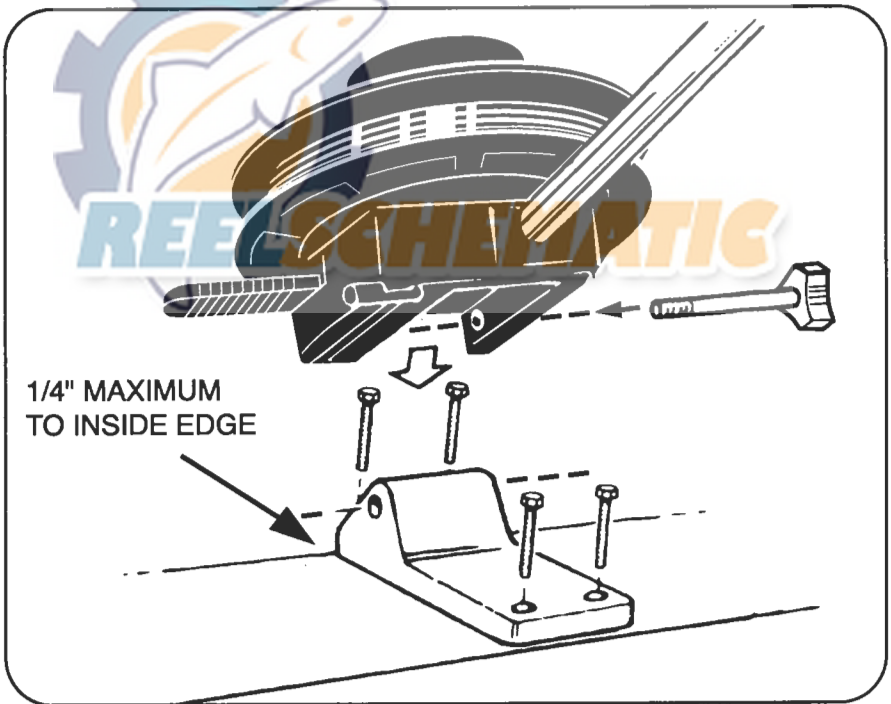

NOTE: If your boat's gunnel configuration does not allow this standard mounting, see the optional mounts on page 11.

R I G G I N G Y O U R F I S H I N G L I N E S

Tighten your downrigger brake by moving it counter clockwise, and attach your weight to the downrigger snap hook. It's best to do this outside the boat so if you drop the weight it won't damage anything. A 7 to 10 pound weight will be sufficient for most fishing conditions.

Clip the snap of the release to the downrigger weight.

Attach your fishing line to the Power Grip release by squeezing the jaws apart and placing your fishing line between the pads. You can adjust the release tension by placing the fishing line further into the jaws. To further increase the release tension you can move the tension adjuster slider to the out position.

With your fishing rod in a rod holder, set the tension on your reel so that the line will pay out, but with enough down drag tension so that it doesn't free wheel. It is important to have your fishing line tight to the Downrigger line because you may lose the fish if he has slack line after releasing off the downrigger.

The downrigger is lowered by moving the brake handle in a clockwise direction. You can go as fast or as slow as you wish, but if you are using a flasher or dodger it is best to descend at a slow, even rate to eliminate fouling the flasher or dodger on the downrigger cable.

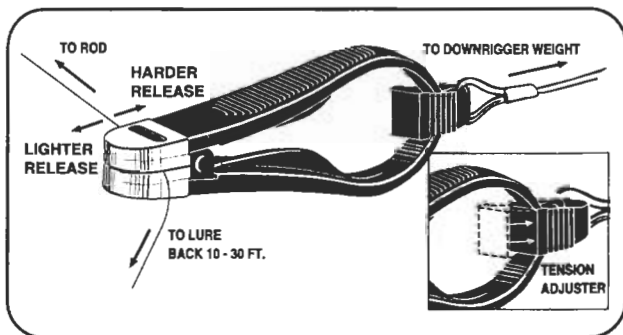
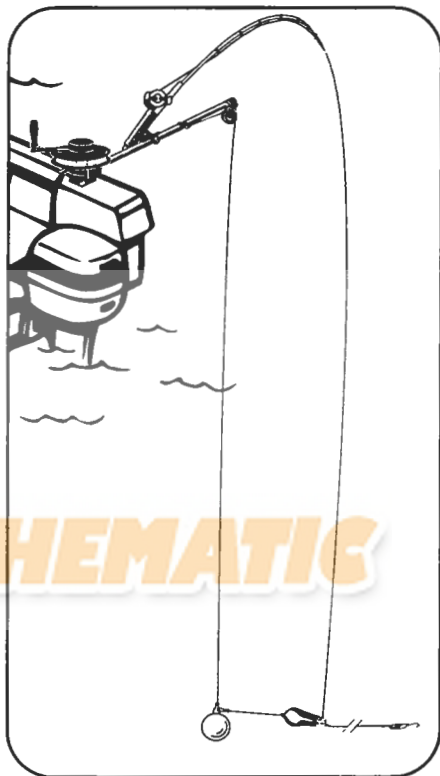

D O W N R I G G E R S D O ' S A N D D O N ' T S

DO Attach your rod and reel line to your Downrigger while your boat is in forward motion. It avoids tangles.

DO Read the depth counter when you catch fish, then go back to the same depth.

DO Replace badly worn wire.

DO Use enough weight (7 to 15 lbs.) on your Downrigger to keep your line at a sharp downward angle, approximately 30 degrees or less when your trolling speed is correct.

DO Keep a pair of wire cutters handy in the event of a serious bottom hang-up.

DO Rinse off your downrigger with freshwater after each use, if used in saltwater.

DON'T Let the Downrigger wire go slack. Kinks may form and also the wire could spill off spool edges.

DON'T Let your fishing reel spin free while you lower your Downrigger. Set a light drag.

DON'T Use nylon or other monofilament line on your Downrigger. Nylon will stretch in use and shrink back on the spool with enough force to damage it. Use of nylon line will void the downrigger warranty.

DON'T Spray downrigger or wire with spray lubricants, oils, etc.

DON'T **Attempt to retrieve a weighted or snagged downrigger cable by hand. Wave or boat motion could cause serious injury.**

C A R E A N D M A I N T E N A N C E

Your Scotty Downrigger is constructed of corrosion resistant materials. Very little maintenance is required. We can pass along a few tips, however that will ensure that your Scotty downrigger will keep up to peak performance.

Routinely check the stainless steel fastenings with a screwdriver to see that they are snug and secure.

Do not use any lubricant on your Scotty, as the material combinations are self-lubricating, and some spray lubricants will attack the plastic components.

It is not advisable to leave the unit in direct sunlight for long periods when not in use. Ultraviolet light will eventually damage any plastic material.

BRAKE ADJUSTMENT

It may be necessary to adjust the brake tension if either the weight does not descent freely or cannot be held when the brake is in the on position.

- (1) Lift up (do not twist) to remove counter cover.
- (2) Remove the Jam Nut, which holds down the counter assembly. Lift the counter assembly off the Downrigger. (It lifts straight up and sometimes requires some gentle prying with two screwdrivers under the opposite edges).
- (3) Using two 9/16 inch wrenches or two small crescent wrenches, hold the bottom nut with one wrench and loosen the top jam nut with the other wrench. With the brake in the off or "6 o'clock" position, either tighten or loosen the bottom nut as required to obtain the correct brake setting.

With a weight on, the brake should engage automatically when the handle is released, yet slip if constant strain is applied to wire.

- (4) Tighten down the Jam Nut and re-assemble the Counter Assembly.

WIRE MAINTENANCE

We have found many things can affect the life of wire. Included in this are such things as an unobserved kink, electrolysis caused by stray electrical currents emanating from the boat, and certain types of jelly fish and minute sea creatures which may have a corroding effect when left on the wire.

Frequent inspection and wiping or washing wire with fresh water may help prolong wire's usefulness.

HOW TO REPLACE WIRE

All our original downrigger wire is fitted with a Scotty snap swivel and crimp-on locator sleeves. If you have occasion to replace the wire, proceed as follows.

Mount the downrigger someplace secure (its regular boat mount is good) and pull off the old wire. When you come to the end of the wire cut the loop off the downrigger spool.

Take the free end of the wire from the supply spool and thread it through the pulley and any fairleads. Thread the wire through the holes from the inside of the spool.

Tie an overhand knot in the wire, pulling it snug against the spool.

Tie a second overhand knot giving you a "square knot" and pull it snug.

The loose end of the wire should be pointing back towards the pulley.

Secure the loose end with tape to keep it from fouling the remainder of the wire line.

Keep tension on the supply spool to wind the new wire on as tight as possible. Avoid twisting or kinking the wire, or winding it onto the spool too loosely. (This operation is best carried out with two people.)

Thread the end of the wire through any fairleads and the pulley, and attach a new Scotty bumper and snap hook.

NOTE: Winding more than 300' of 150 lb. test wire onto the spool will affect the accuracy of the depth counter, use of heavier test wire will also affect the counter accuracy.

OPTIONAL MOUNTS

FOR MODELS No. 1050 AND 1060 ONLY

No. 1015

Right Angle Side Gunnel Mount

For boats with narrow or uneven gunnels.

- Dimensions: 5 1/4" x 2 1/2"
- Bolting Dimensions: 4 9/16" x 1 5/8"
- Includes S.S. bolts to fasten mounting bracket.

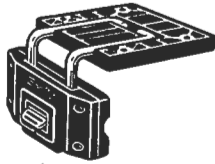

No. 1021

Clamp Mount

For portable downrigger fishing from aluminum boats

- Dimensions: 5 5/8" x 4 3/4" x 3 1/8"
- Clamp opening: 2"
- Includes S.S. bolts to fasten mounting bracket.

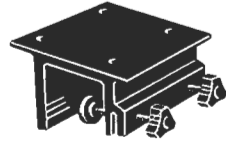

FOR ALL MODELS

No. 1025

Right Angle Side Gunnel Mount

For boats with narrow or uneven gunnels. Strong and durable, with quick fastening stainless steel bolts for easy set up and removal.

- Fits No. 1026 swivel mount.
- Dimensions: 6" x 6" x 6"
- Bolting dimensions: 4" x 2"
- Includes S.S. bolts to fasten mounting bracket.

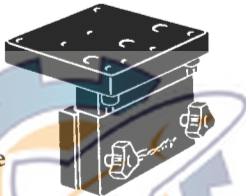

No. 1026

Pedestal/Swivel Mount

Gives full 360° rotation with 16 locking positions, with quick fastening stainless steel bolts for easy set up and removal.

- Dimensions: 5 1/2" x 5 1/2" x 3 5/8"
- Bolting dimensions: 4 1/2" x 3 1/2"
- Includes S.S. bolts to fasten mounting bracket.

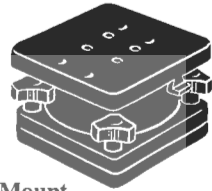

No. 1027

Rail Mount

For all downriggers, fits up to 1 1/2" round rail, or oval-shaped wooden rails. Easily installed and removed for storage. wooden board (not included) transfers the downward pressure to the boat gunnel.

- Fits No. 1026 swivel mount.
- Dimensions: 6 1/8" x 7 1/8"
- Includes S.S. bolts to fasten mounting bracket.

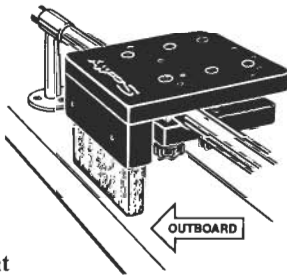

No. 1028/1029

Gimbal Mount - 9" or 12"

Fits into boat's flush mount rod holder. Eliminates drilling holes and permanent mounting of downrigger brackets on boat. Made from welded stainless steel and modified nylon for the ultimate in strength and durability.

- Fits No. 1026 swivel mount.
- Dimensions:
 - No. 1028 - 6 1/8" x 7 1/8" x 9" x 1 1/2"
 - No. 1029 - 6 1/8" x 7 1/8" x 12" x 1 3/4"
- Includes S.S. bolts to fasten mounting bracket.

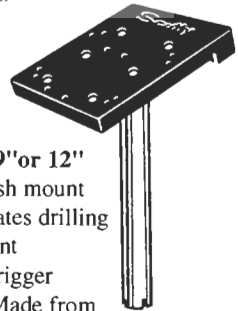

**TO OBTAIN PARTS, INFORMATION OR TO LOCATE THE
WARRANTY SERVICE DEPOT NEAREST YOU CONTACT:**

**SCOTTY FISHING
AND MARINE PRODUCTS
2065 HENRY AVE. WEST**

SIDNEY, BC CANADA

V8L 5Z6

TEL: (250) 656-8102

FAX: (250) 656-8126

Toll Free: 1-800-214-0141

E-mail: scotty@scotty.com



w w w . s c o t t y . c o m



Although Scotty makes every effort to ensure the accuracy of specifications at the time of publication, specifications for products described in this publication are subject to change without notice. Contact Scotty for the most current information.

1-800-214-0141



Recycled Paper

Printed in Canada May / 03